



HCPPT-01P

High Capacity Prep Table Refrigerator - Propane



Overview

- 15% reduction in energy consumption over R134a version
- Cartridge refrigeration system, removable for easy maintenance
- Fits virtually all existing Prep Tables
- ENERGY STAR rated
- Environmentally-friendly R290 Propane refrigerant 



Certifications

H&K International
 2200 Skyline Drive,
 Mesquite, TX 75149
 USA
 Tel: +1 800-788-2445
 Fax: +1 214-818-3596

H&K Equipment Ltd
 1 Cosford Lane
 Swift Valley
 Rugby CV21 1QN
 United Kingdom
 Tel: +44 (0) 1788 554000
 Fax: +44 (0) 1788 554100

H&K Manufacturing Ltd
 Knockmitten House
 Knockmitten Lane
 Dublin 12
 Republic of Ireland
 Tel: +353 (1) 6055400
 Fax: +353 (1) 6055466

Contact Info

www.hki.com

HCPPT High Capacity Prep Table Refrigerator

Plans

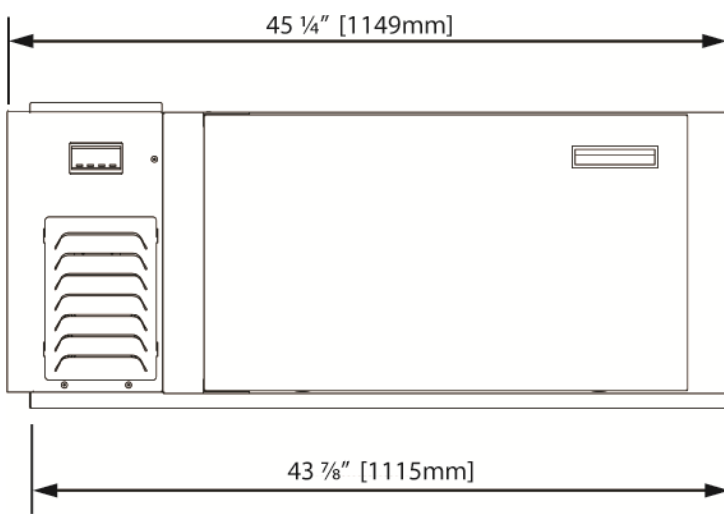

Front

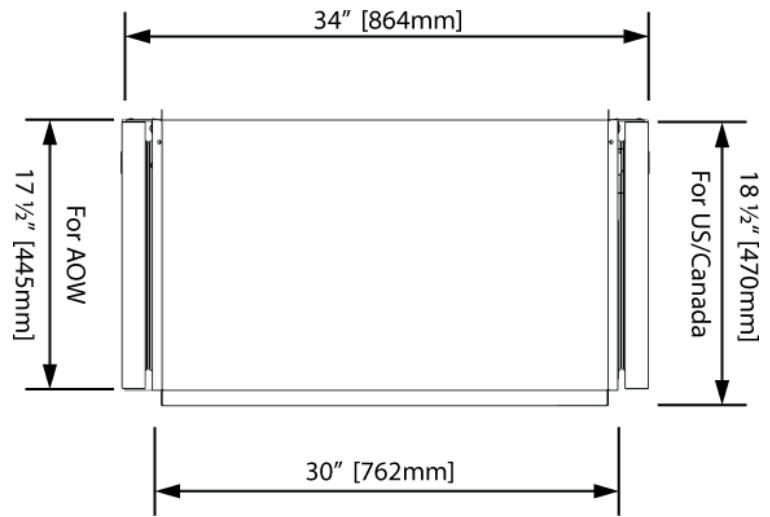

Side View

Weights & Dimensions

in/lbs/ft³

mm/kg/L

Shipping

Weight	300	136
--------	-----	-----

Operational

Depth	30	762
Width	45 1/4	1149
Height	18 1/2	470
Capacity	8	227
Weight	225	102
Side Clearance	N/A	N/A
Back Clearance	N/A	N/A
Top Clearance	N/A	N/A

Electrical & Mechanical

US/Canada/LATAM

AOW

Japan

Voltage/Phase/Frequency	120/1/60	230/1/50-60	
Amps	2.8	1.4	
Material (Ext./Int./Doors&Lids)		SS/SS/SS	
Operating Temp		32°F - 41°F (0°C - 5°C)	
Refrigerant		R290 4.6oz (0.130kg)	
Plug/Cord Type		by market, 7'-0" (2.1 m*)	*By local code
Controls		Digital, Self Defrosting	



H&K International
Restaurant Equipment Systems Worldwide

www.hki.com
1.800.859.2445