

Place this manual in the Toaster section
of your Equipment Manual.
Manufactured exclusively for
McDONALD'S®

BY
A.J. ANTUNES & CO.
180 KEHOE BLVD.
CAROL STREAM, ILLINOIS 60188, U.S.A.
PHONE: 1-630-784-1000
TOLL FREE: 1-877-392-7854
FAX: 1-630-784-1650
www.ajantunes.com



A.J. Antunes & Co.



HCT-5H & HRT-5H

Scan with mobile device or enter URL
for product and service information.

<http://tiny.cc/ajaHCT-HRT>

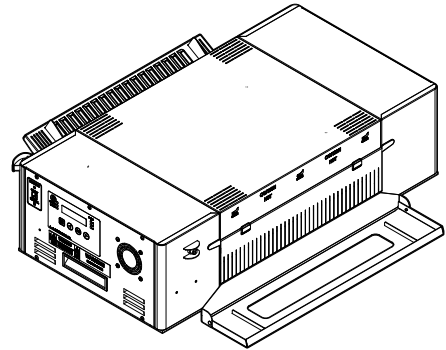

TABLE OF CONTENTS

Owner Information	2	Programming	7
General	2	Control Panel	7
Service/Technical Assistance	2	Settings	7
Warranty Information	2	Purging Product from Toaster	7
Specifications	3	Factory Reset	7
Electrical Specifications & Plug Configuration	3	Maintenance	8
Dimensions	3	Daily Cleaning	8
Important Safety Information	4	Removing/Installing Conveyor Belt Chain	9
Installation	5	Troubleshooting	10
Unpacking	5	Replacement Parts	13
Location	5	Wiring Diagram	19
Operation	6		
Operating Instructions	6		
Muffin/Bagel Mode	6		
Language Selection	6		

LIMITED WARRANTY

The Antunes Food Service Equipment Division of A.J. Antunes & Co. provides the following limited warranty to the original purchaser of all McDonald's Equipment. All components are warranted against defects in the material and workmanship for a period of two (2) years from date of original installation.

If any part becomes defective during the period of this Warranty, Antunes Food Service will pay labor costs to an Authorized Service Agent to replace the part plus travel expenses.

WARRANTY EXCLUSIONS

- The cost of Installation.
- Equipment that has been damaged due to shipment. Purchaser should make damage claim directly upon carrier.
- Alteration, misuse, abuse.
- Improper storage or handling.
- Improper maintenance.
- Failure to follow proper Installation instructions, including electrical connection.
- Improper or unauthorized repairs.
- Scheduled Maintenance procedures as outlined in your MRC Card.

- This Warranty does not cover Consumable items. **NOTE:** *The wire Conveyor Belt Chain and the front/rear Heat Damper Curtains are consumable items that can be easily adjusted or replaced according to the Maintenance Section of this product's Owner's Manual.*
- Water pressure problems or contamination problems such as foreign material in water lines or inside solenoid valves due to an incoming water source.
- Freight, foreign, excise, municipal or other sales or use taxes.
- Consequential damages such as loss of profit, loss of time, the cost of repairing or replacing other property which is damaged, or any other incidental damage of any kind.

Antunes Food Service reserves the right to make changes in design or add improvements on any products. The right is always reserved to modify Equipment because of factors beyond our control and government regulation. Changes to Equipment do not constitute a warranty charge.

This warranty is exclusive and is in lieu of all other warranties, expressed or implied, including any implied warranty of merchantability or fitness for a particular purpose, each of which is expressly disclaimed. The remedies described above are exclusive, and in no event shall A.J. Antunes & Co. or any of its Divisions be liable for special consequential or incidental damages for the breach or delay in the performance of this warranty.

This manual is for the exclusive use of licensees and employees of McDonald's Systems, Inc..

© McDonald's Corporation All Rights Reserved

OWNER INFORMATION

General

This manual provides the safety, installation, and operating procedures for this unit. Please read this manual prior to installing and operating the unit.

This unit is manufactured from the finest materials available and assembled to Roundup's strict quality standards. This unit has been tested at the factory to ensure dependable trouble-free operation.

Service/Technical Assistance

If you experience any problems with the installation or operation of your unit, contact your Authorized Service Agency.

Warranty Information

Please read the full text of the Limited Warranty in this manual.

If the unit arrives damaged, contact the carrier immediately and file a damage claim with them. Save all packing materials when filing a claim. Freight damage claims are the responsibility of the purchaser and are not covered under warranty.

The warranty does NOT extend to:

- Damages caused in shipment or damage as result of improper use.
- Installation of electrical service.
- Normal maintenance as outlined in this manual.
- Malfunction resulting from improper maintenance.
- Damage caused by abuse or careless handling.
- Damage from moisture into electrical components.
- Damage from tampering with, removal of, or changing any preset control or safety device.

Fill in the information below and have it handy when calling your Authorized Service Agency for assistance. The serial number is on the specification plate located on the rear of the unit.

Purchased From: _____

Date of Purchase: _____

Model No.: _____

Serial No.: _____

Mfg. No.: _____

Network ID Number: _____

Refer to the service agency directory packaged with your manual and fill in the information below:

Authorized Service Agency

Name: _____

Phone No.: _____

Address: _____

Use only genuine Roundup replacement parts in this unit. Use of replacement parts other than those supplied by the manufacturer will void the warranty. Your Authorized Service Agency has been factory trained and has a complete supply of parts for this toaster.

You may also contact the factory at 1-877-392-7854 (North America only), or 630-784-1000 if you have trouble locating your local Authorized Service Agency.

IMPORTANT! Keep these instructions for future reference. If the unit changes ownership, be sure this manual accompanies the equipment.

SPECIFICATIONS

Electrical Specifications & Plug Configuration

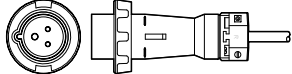
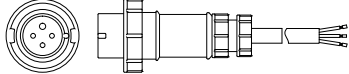
Model & Mfg. No	Volt	Watts	Hz.	Plug Description	Plug Configuration
HRT-5H 9210852 (Domestic)	208	4430-5250	60	Pin & Sleeve Plug 30 Amps, 250 VAC	
HRT-5H 9210523 (Domestic)	208	5000	60	Power Cord Assy., 3 Ph, Plug 1 PH Cord, 250V 30A	

⚠ CAUTION ⚠

All electrical connections must be in accordance with local electrical codes and any other applicable codes.

Dimensions

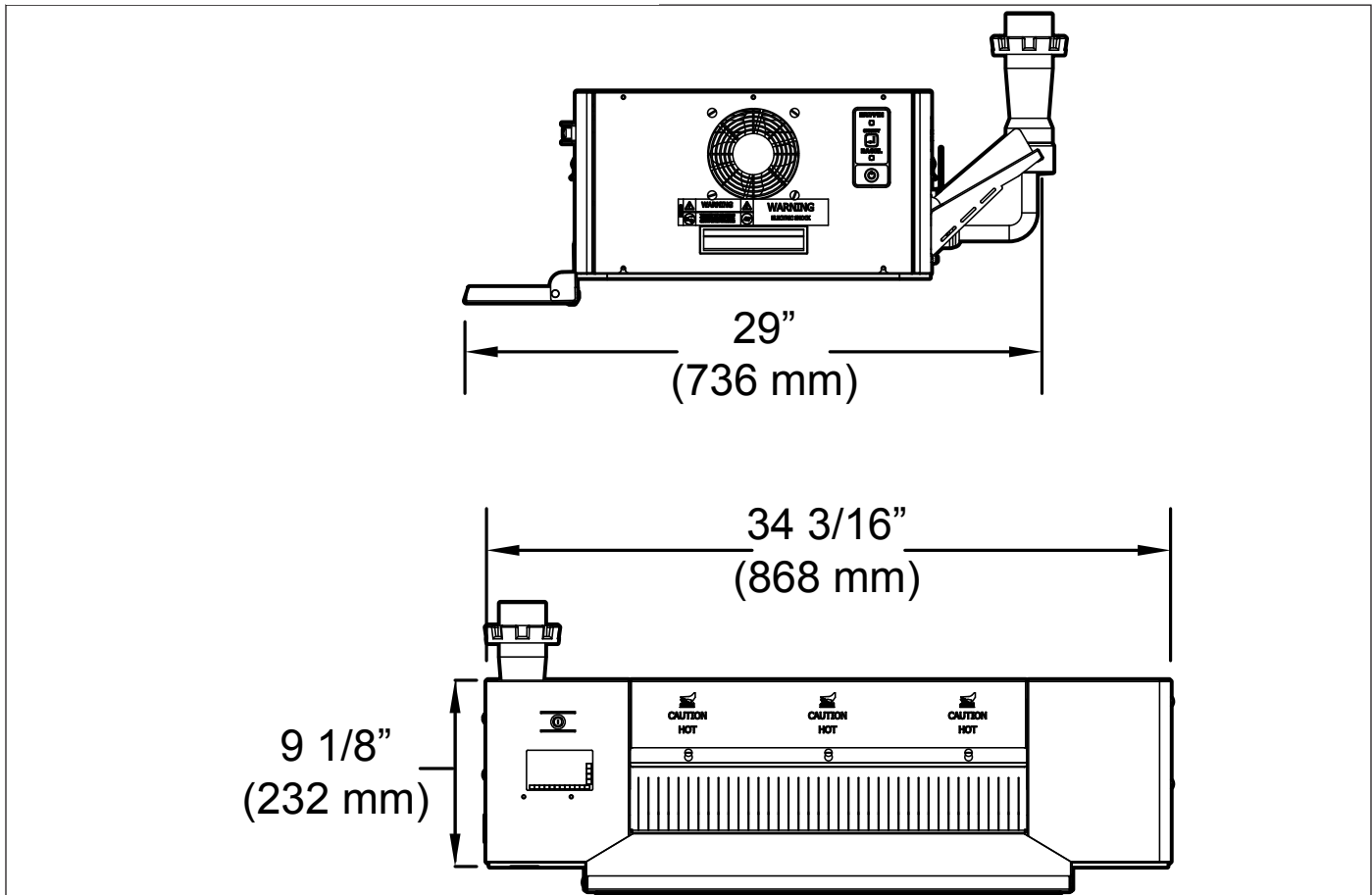

IMPORTANT SAFETY INFORMATION

In addition to the warnings and cautions in this manual, use the following guidelines for safe operation of the unit.

- Read all instructions before using equipment.
- For your safety, the equipment is furnished with a properly grounded cord connector. Do NOT attempt to defeat the grounded connector.
- Install or locate the equipment only for its intended use as described in this manual. Do NOT use corrosive chemicals in and/or on this equipment.
- Do NOT operate this equipment if it has a damaged cord or plug, if it is not working properly, or if it has been damaged or dropped.
- This equipment should be serviced by qualified personnel only. Contact the nearest Authorized Service Agency for adjustment or repair.
- Do NOT block or cover any openings on the unit.
- Do NOT immerse cord or plug in water.
- Keep cord away from heated surfaces.
- Do NOT allow cord to hang over edge of table or counter.
- Do NOT clean this appliance with a water jet.

The following warnings and cautions appear throughout this manual and should be carefully observed.

- Turn the unit off, wait for the cool-down procedure to complete its cycle, and disconnect the power cord before performing any service or maintenance on the unit.

NOTE: Turning off the power switch does NOT turn off all power to the unit. When the unit is plugged in and turned off, an LED light flashes to indicate that the power cord is plugged in.

- The procedures in this chapter may include the use of chemical products. These chemical products will be highlighted with bold face letters followed by the abbreviated **HCS** (Hazard Communication Standard). See Hazard Communication Standard manual for the appropriate Material Safety Data Sheets (MSDS).
- The equipment should be grounded according to local electrical codes to prevent the possibility of electrical shock. It requires a grounded receptacle with separate electrical lines, protected by fuses or circuit breaker of the proper rating.

- Bread may burn. Therefore toasters must not be used near or below curtains or other combustible walls and materials. Failure to maintain safe operating distances may cause discoloration or combustion.

⚠ WARNING ⚠

To avoid possible personal injury and/or damage to the unit, all inspections, tests, and repair of electrical equipment should be performed by QUALIFIED SERVICE PERSONNEL. The unit MUST be completely shut down and unplugged before any internal servicing, except when electrical tests are required. Use extreme care during electrical circuit tests. Live circuits will be exposed.

⚠ CAUTION ⚠

All electrical connections must be in accordance with local electrical codes and any other applicable codes.

⚠ CAUTION ⚠

Bread may burn. Therefore toasters must not be used near or below curtains or other combustible walls and materials. Failure to maintain safe operating distances may cause discoloration or combustion.

⚠ CAUTION ⚠

NEVER unplug the power cord while the unit is running! Use the proper shutdown procedure before unplugging the power cord.

⚠ WARNING ⚠

ELECTRICAL SHOCK HAZARD. FAILURE TO FOLLOW THE INSTRUCTIONS IN THIS MANUAL COULD RESULT IN SERIOUS INJURY OR DEATH.

- Electrical ground is required on this appliance.
- Do NOT modify the power supply cord plug. If it does not fit the outlet, have a proper outlet installed by a qualified electrician.
- Do NOT use an extension cord with this appliance.
- The toaster should be grounded according to local electrical codes to prevent the possibility of electrical shock. It requires a grounded receptacle with separate electrical lines, protected by fuses or circuit breaker of the proper rating.
- Check with a qualified electrician if you are unsure if the appliance is properly grounded.

INSTALLATION

Unpacking

1. Open the large box. It contains:
 - HRT-5H toaster
 - Accessories box
2. Remove the accessories box from the large box.
3. With the help of another person, carefully remove the HRT-5H from the large box.
4. Remove all protective coverings from the unit.
5. Open the Accessories Box. It contains:
 - Owner's Manual
 - Feeder
 - Tray
 - Tray Holder
6. Wipe the entire exterior of the toaster and the accessories mentioned above with a clean towel sprayed with a McDonald's approved sanitizer. Allow to air dry.

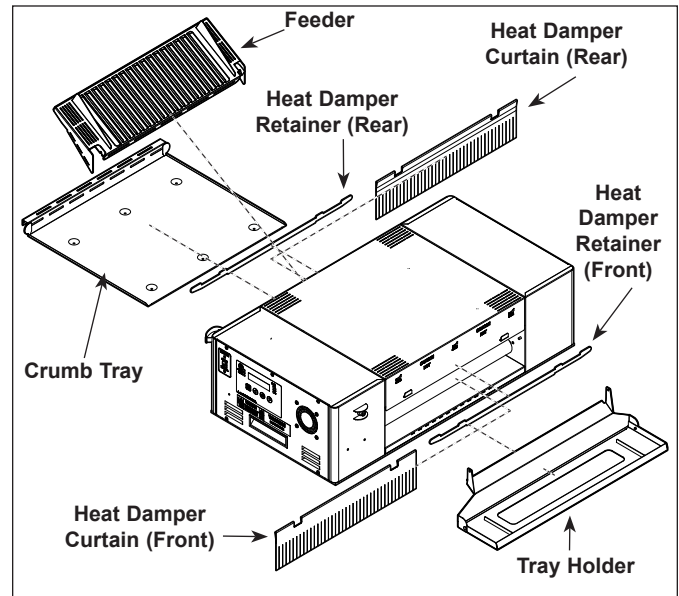

Figure 1. HRT-5H Components

NOTE: Handle accessories with care. If an accessory becomes bent or damaged, it may not attach to the unit correctly, which may affect normal operation.

NOTE: If any parts are missing or damaged, contact A.J. Antunes Technical Service IMMEDIATELY at 1-877-392-7854 (North America only), or 630-784-1000.

Location

When placing the toaster into service, pay attention to the following guidelines:

- Make sure power is off and the toaster is at room temperature.
 - Do NOT block or cover any openings on the unit.
 - Do NOT immerse cord or plug in water.
 - Keep cord away from heated surfaces.
 - Do NOT allow cord to hang over edge of table or counter.
1. Place the toaster in the required position designated by McDonald's.
 2. Attach the Bun Feeder, Crumb Tray, and Tray Holder, and Tray (Figure 1).
 3. Plug the power cord into an appropriate power outlet. Refer to the specification plate for the proper voltage.

OPERATION

Operating Instructions

NOTE: The toaster starts up in Muffin Mode.

Follow these steps to start the toaster:

1. Plug in the power cord. Press and release the Power Button to turn on. Wait for warm-up to complete (approximately 20 minutes).

NOTE: The HRT-5H has two Power Buttons: one on the Control Panel and one on the opposite side of the toaster. Both perform exactly the same.

2. When the unit reaches operating temperature, the control panel displays "Muffin Ready".
3. Insert product into the designated area of the Feeder with the cut side facing UP. Toasted product drops into the Tray.

Muffin/Bagel Mode

To switch to Bagel Mode, press and release one of the Muffin/Bagel buttons on the unit. The toaster will display "Bagel Ready." Press the Muffin/Bagel button again to switch back to Muffin Mode.

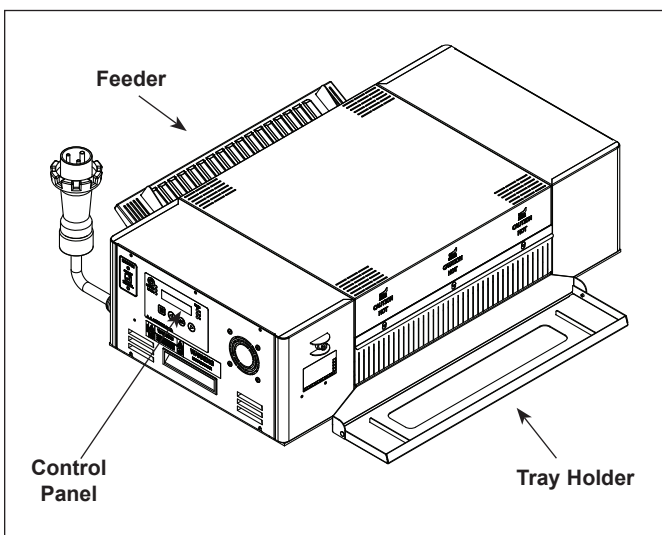

Figure 2. HRT-5H

Language Selection

Follow these steps to set the language option for the toaster.

1. Plug in the power cord and turn the toaster on.
2. See Figure 3. Press and hold the **MENU** button for five seconds.
3. Press the **LEFT ARROW** button until the display shows "English".
4. Press the **OK** button.
5. Use the **LEFT** and **RIGHT ARROW** buttons to select your preferred language. The available languages appear in the following order:
 - English
 - Spanish
 - French Canadian
6. Press the **OK** button to save the changes.
7. Return the toaster to service.

PROGRAMMING

Control Panel

Access the Control Panel by facing the front of the unit and moving to the left side of the unit. The LEDs on the control panel light to signify when each item is operating. The Service LED lights and the corresponding LED blinks when the unit requires service. A message also appears on the display.

Settings

Follow the steps below to view and adjust the settings of the HRT-5H.

1. When the unit is plugged in, press and hold the **MENU** button (Figure 4) for five seconds. The control panel displays "Heater A" The display shows the setpoint, operating current, and SSR Duty cycle.

NOTE: The unit does not have to be turned on in order to access the settings menu.

2. Use the **LEFT** and **RIGHT** arrow buttons (Figure 4) to scroll through the settings, which appear in the following order:
 - Heater A
 - Heater B
 - Heater C
 - Muffin Toast Color
 - Bagel Toast Color
 - Units (°F/°C)
 - Buzzer (On/Off)
 - Languages
 - Service Messages
 - Control Temperatures
 - Motor (view only)
 - Conveyor (view only)
 - System Temperatures (view only)
3. To change a setting, press the **OK** button and then use the **LEFT** and **RIGHT** arrow buttons to adjust as needed. Press the **OK** button again to save the changes. See Figure 4.

The table below describes the default settings for Heaters A, B, and C:

Value	Default Setting
Heater A & B	65%*
Heater C	0 %*
Units	°F
Buzzer	ON
Muffin Toast Color	750*
Bagel Toast Color	500*

***Do NOT Adjust these settings.**

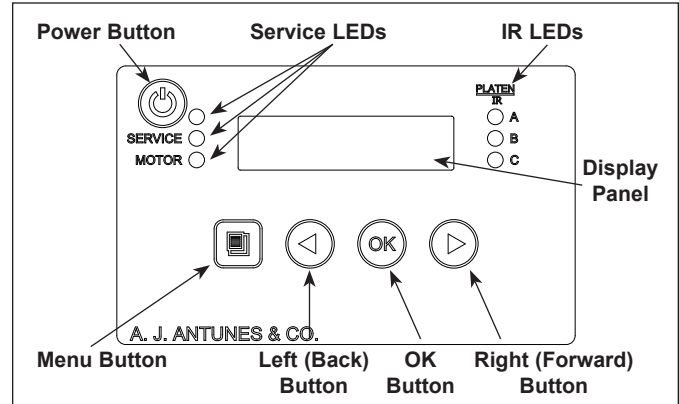

Figure 3. HRT-5H Control Panel

Factory Reset

To reset the unit to the factory default settings:

1. Turn the unit off
2. Press and hold the **LEFT** and **RIGHT** arrow buttons and turn the unit on.
3. The toaster displays "Factory Settings Restored" on the display.

NOTE: For ALL Units, this sets the display temperature to °F (Fahrenheit). Refer to the "Settings" section of this manual to change the display temperature to °C (Celsius).

NOTE: System Temperatures, Controls Temperatures, and Conveyor cannot be adjusted.

Light/Dark Adjustment

When the unit is turned on and ready, you can adjust the toast quality by pressing the **LEFT** and **RIGHT** arrow buttons on the control panel. After making an adjustment, test several products to verify they are toasting at the desired quality.

NOTE: This setting is maintained when the unit is powered off.

Purging Product from Toaster

To purge product from the toaster, press and hold the **LEFT** and **RIGHT** arrow buttons. This speeds up the conveyors to force product out of the front of the toaster.

NOTE: If at any time the unit displays an error message or if it fails to operate properly, contact the factory immediately for service.

MAINTENANCE

Daily Cleaning

1. Press and release the Power Button to turn the toaster off. The toaster enters a cool-down mode and automatically shuts down when complete.

NOTE: You do NOT need to wait for the cool down to complete.

NOTE: The Conveyor Belt Chain continues to turn during the cool-down period, allowing you to clean the entire Conveyor Belt Chain.

2. Put on neoprene gloves. Remove the Bun Feeder, Crumb Tray, and Tray Holder, and Tray (Figure 4).
3. Wash the Bun Feeder, Crumb Tray, Tray Holder, and Tray at the three-compartment sink. Allow to air dry.
4. Clean the outside surfaces of the toaster with a paper towel sprayed with an approved multi-surface cleaner. Allow to air dry.

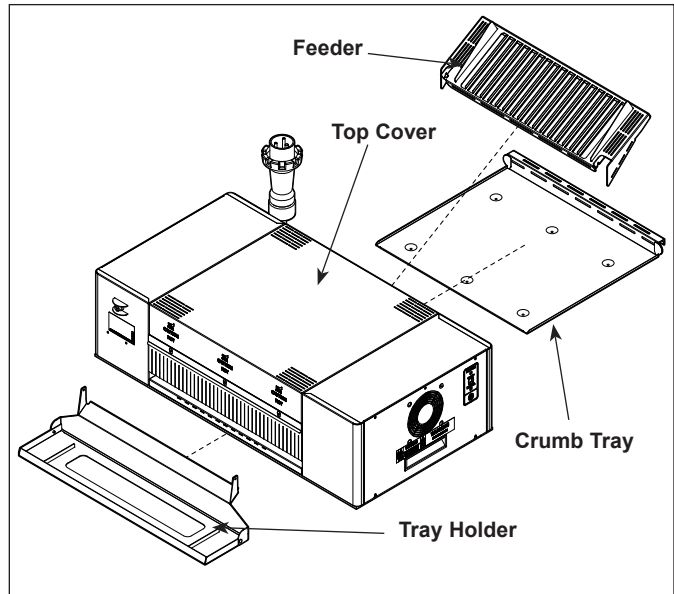

Figure 4. HRT-5H Components

CLEANING AND SANITIZING THE BELTS (DAILY)

5. From the rear of the unit (Figure 5), inspect the Conveyor Belt Chain for any damage. Replace if needed.
5. If the Conveyor Belt Chain is in good condition, spray a clean, sanitized towel with an approved multi-surface cleaner. Wipe the Conveyor Belt Chain for one revolution.

NOTE: You may need to wipe the Conveyor Belt Chain for more than one revolution.

6. Spray a clean, sanitized towel with an approved sanitizer. Wipe the Conveyor Belt Chain for one revolution.
7. Re-install the Bun Feeder, Crumb Tray, Tray Holder, and Tray.
9. Press and release the Power Button to turn the toaster on. Return to normal operation.

MAINTENANCE (continued)

Removing/Installing Conveyor Belt Chain

The Conveyor Belt Chain is considered a consumable item which can be easily adjusted or replaced.

The diagram below provides the procedure for removing and installing links to the Conveyor Belt Chain. This diagram also provides the procedure for removing and replacing the entire Conveyor Belt Chain.

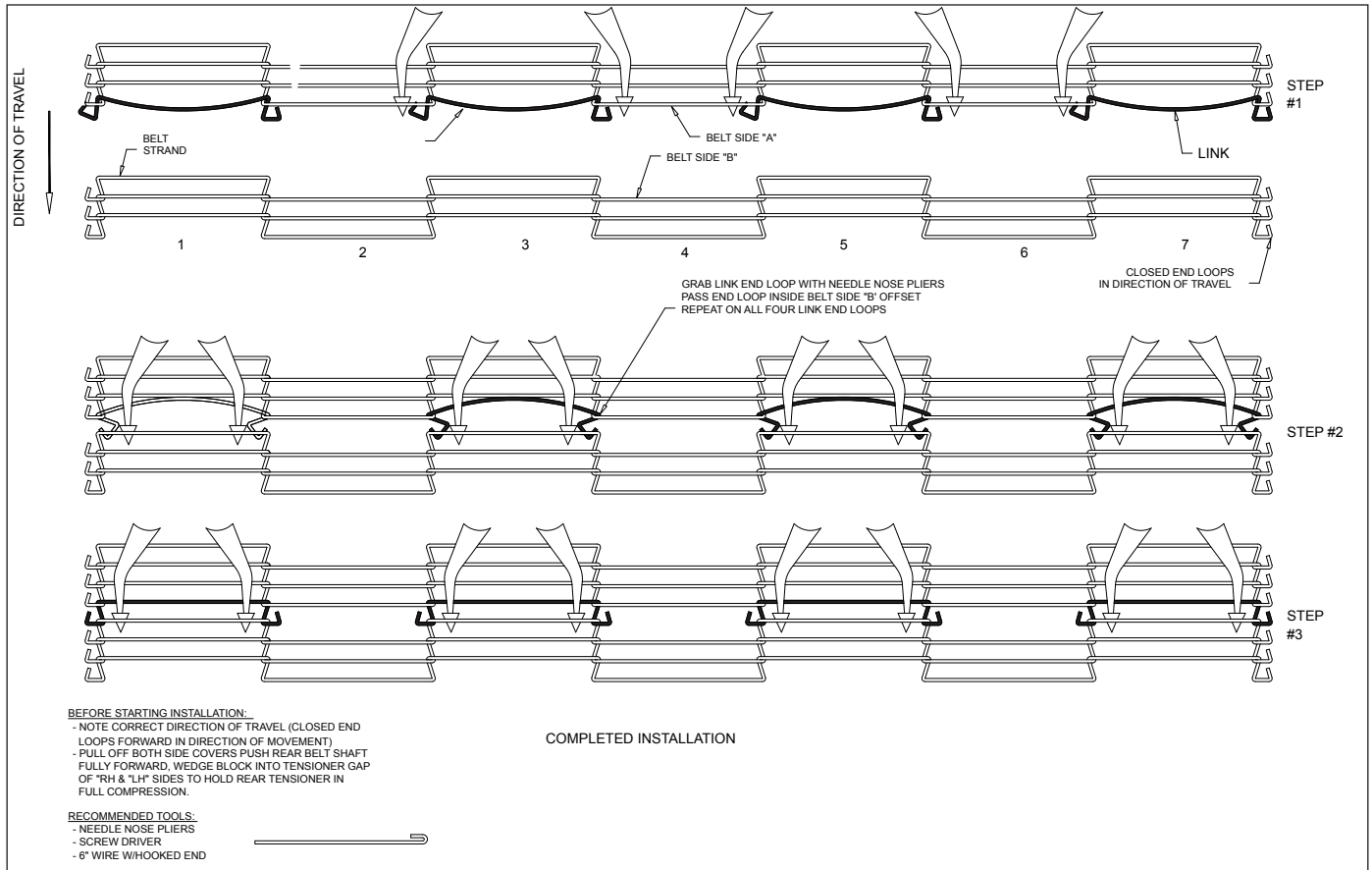

TROUBLESHOOTING

⚠️ WARNING ⚠️

To avoid possible personal injury and/or damage to the unit, inspection, test and repair of electrical equipment should be performed by qualified service personnel. The unit should be unplugged when servicing, except when electrical tests are required.

If the troubleshooting steps listed do not solve your machine problem, contact an Authorized Service Agency for further assistance or service.

Problem	Possible Cause(s)	Corrective Action
Display Reads "Hi-Limit Tripped"	Hi-Limit has tripped.	Remove black cap & firmly press the green button. Contact AJA Technical Support 877-392-7854 for assistance
Display Reads "Conveyor Stopped"	A Mechanical Obstruction has occurred which completely stalled the conveyor motor	Check the bottom wire conveyor belt & surrounding areas for any obstructions/jams. Call AJA Technical Support 877-392-7854 for assistance
	Wire conveyor belt is too loose/sagging & getting jammed	If sagging is noticeable, proceed & remove necessary links to shorten up the belt. Call AJA Technical Support 877-392-7854 for assistance
	Wire conveyor belt is broken/damaged & jammed.	Replace wire belt. Call AJA Technical Support 877-392-7854 for assistance
Display Reads "Motor Running Slow"	A Mechanical Obstruction has occurred that is slowing down the conveyor motor	Check the bottom wire conveyor surrounding areas for any obstructions/jams. Call AJA Technical Support 877-392-7854 for assistance
	Wire conveyor belt is too loose/sagging & getting jammed	If sagging is noticeable, proceed & remove necessary links to shorten up the belt. Call AJA Technical Support 877-392-7854 for assistance
	Wire conveyor belt is broken/damaged & jammed.	Replace wire belt. Call AJA Technical Support 877-392-7854 for assistance
Display Reads "Motor Slow"	A Mechanical Obstruction has occurred that is slowing down the conveyor motor	Check the bottom wire conveyor surrounding areas for any obstructions/jams. Call AJA Technical Support 877-392-7854 for assistance
	Wire conveyor belt is too loose/sagging & getting jammed	If sagging is noticeable, proceed & remove necessary links to shorten up the belt. Call AJA Technical Support 877-392-7854 for assistance
	Wire conveyor belt is broken/damaged & jammed.	Replace wire belt. Call AJA Technical Support 877-392-7854 for assistance
Display Reads "Motor Load"	A Mechanical Obstruction has occurred that is slowing down the conveyor motor	Check the bottom wire conveyor surrounding areas for any obstructions/jams. Call AJA Technical Support 877-392-7854 for assistance
	Wire conveyor belt is too loose/sagging & getting jammed	If sagging is noticeable, proceed & remove necessary links to shorten up the belt. Call AJA Technical Support 877-392-7854 for assistance
	Wire conveyor belt is broken/damaged & jammed.	Replace wire belt. Call AJA Technical Support 877-392-7854 for assistance
Display Reads "Control Temperature Fail"	Toaster Electrical compartment is overheating due to Lack of airflow surrounding the toaster	Inspect the cooling fan on the side for operation & ensure it is clean. Call AJA Technical Support 877-392-7854 for assistance

TROUBLESHOOTING (continued)

Problem	Possible Cause(s)	Corrective Action
Display Reads "Motor Temperature Fail"	Toaster Electrical compartment is overheating due to Lack of airflow surrounding the toaster	Inspect the cooling fan on the side for operation & ensure it is clean. Call AJA Technical Support 877-392-7854 for assistance
Display Reads "Internal Fault"	Control Board Malfunction	Cycle Power OFF/ON. If message persists, then Call AJA Technical Support 877-392-7854 for assistance
Display Reads "Internal Error"	Control Board Malfunction	Cycle Power OFF/ON. If message persists, then Call AJA Technical Support 877-392-7854 for assistance
Display Reads "SSR A Fail"	The solid state relay for Heater A has failed	Cycle Power OFF/ON. If message persists, then Call AJA Technical Support 877-392-7854 for assistance
Display Reads "Sensor A Fail"	Thermocouple A has failed	Cycle Power OFF/ON. If message persists, then Call AJA Technical Support 877-392-7854 for assistance
Display Reads "SSR B Fail"	The solid state relay for Heater B has failed	Cycle Power OFF/ON. If message persists, then Call AJA Technical Support 877-392-7854 for assistance
Display Reads "Sensor B Fail"	Thermocouple B has failed	Cycle Power OFF/ON. If message persists, then Call AJA Technical Support 877-392-7854 for assistance
Display Reads "SSR C Fail"	The solid state relay for Heater C has failed	Cycle Power OFF/ON. If message persists, then Call AJA Technical Support 877-392-7854 for assistance
Display Reads "Sensor C Fail"	Thermocouple C has failed	Cycle Power OFF/ON. If message persists, then Call AJA Technical Support 877-392-7854 for assistance
Display Reads "USB Power"	An unauthorized device has been plugged into the rear USB Port that is over loading the USB port.	Remove the device from the port. NOTE: Only approved devices for special toaster software loading should be used. Call AJA Technical Support 877-392-7854 for assistance
No Display	Power Cord is not plugged into the outlet	Unplug the power cord then firmly plug back in
	No power at outlet	Contact your electrician
	Circuit Breaker is Tripped or OFF	Reset circuit breaker
	Equipment malfunction	Call AJA Technical Support 877-392-7854 for assistance

TROUBLESHOOTING (continued)

Problem	Possible Cause(s)	Corrective Action
Muffins/Bagels are toasting too light	Programmed settings have been inadvertently changed	Perform a factory reset as detailed in "Programming Section" of this owner's manual. Call AJA Technical Support 877-392-7854 for assistance
	Light/Dark settings must be adjusted	Adjust the Light/Dark settings to achieve a darker product. Call AJA Technical Support 877-392-7854 for assistance
	Using refrigerated product	Verify that only room temperature product is being used
	The front &/or rear curtain is damaged/missing several slits	Replace both curtains if damaged/missing. Call AJA Technical Support 877-392-7854 for assistance
Muffins/Bagels are toasting too dark	Programmed settings have been inadvertently changed	Perform a factory reset as detailed in "Programming Section" of this owner's manual. Call AJA Technical Support 877-392-7854 for assistance
	Wire conveyor belt is too loose/sagging causing it to skip/hesitate on sprockets	If sagging is noticeable, proceed & remove necessary links to shorten up the belt. Call AJA Technical Support 877-392-7854 for assistance
	Light/Dark settings must be adjusted	Adjust the Light/Dark settings to achieve a lighter product. Call AJA Technical Support 877-392-7854 for assistance
	The front &/or rear curtain is damaged/missing several slits	Replace both curtains if damaged/missing. Call AJA Technical Support 877-392-7854 for assistance

REPLACEMENT PARTS

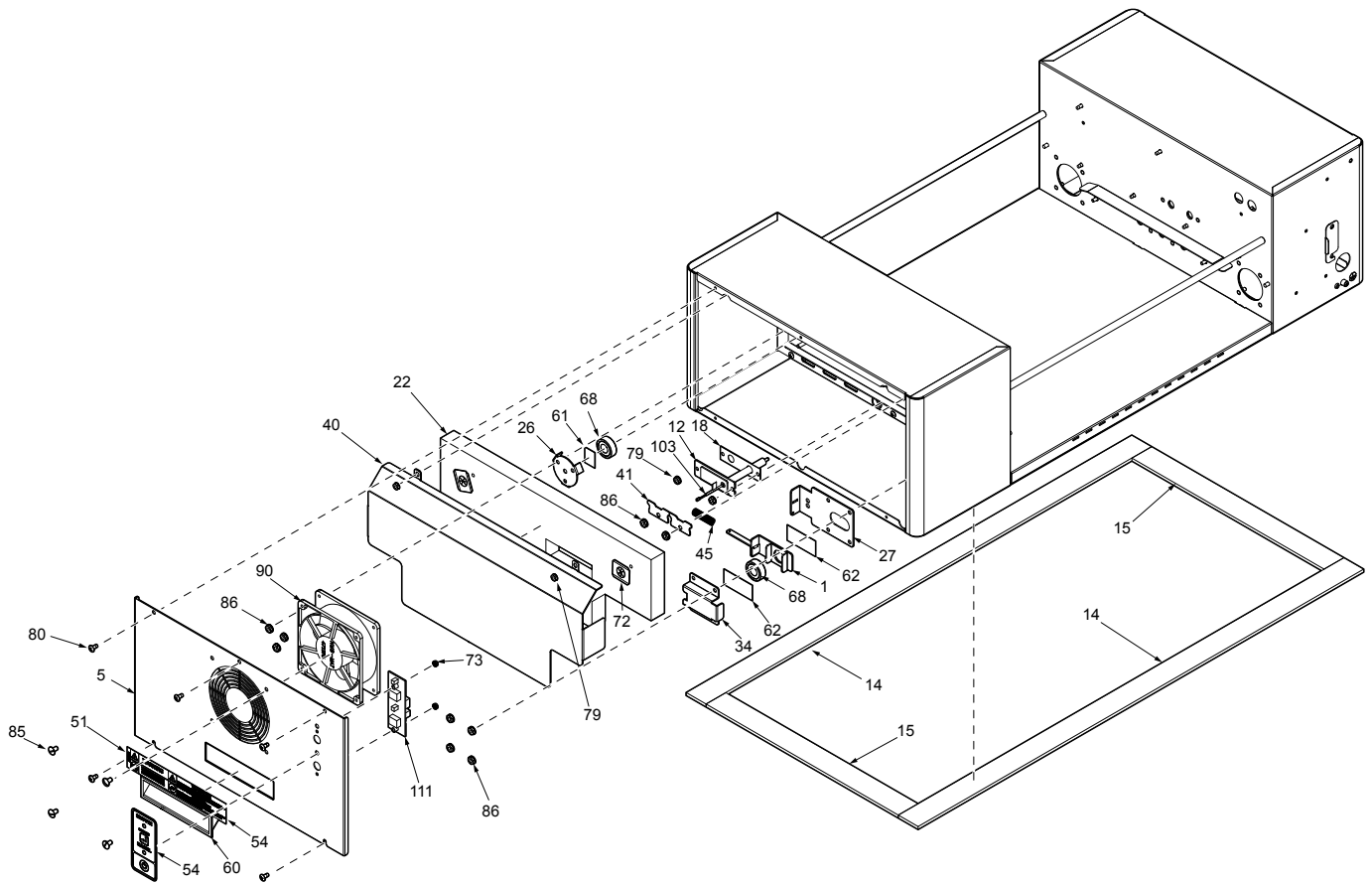

REPLACEMENT PARTS (continued)

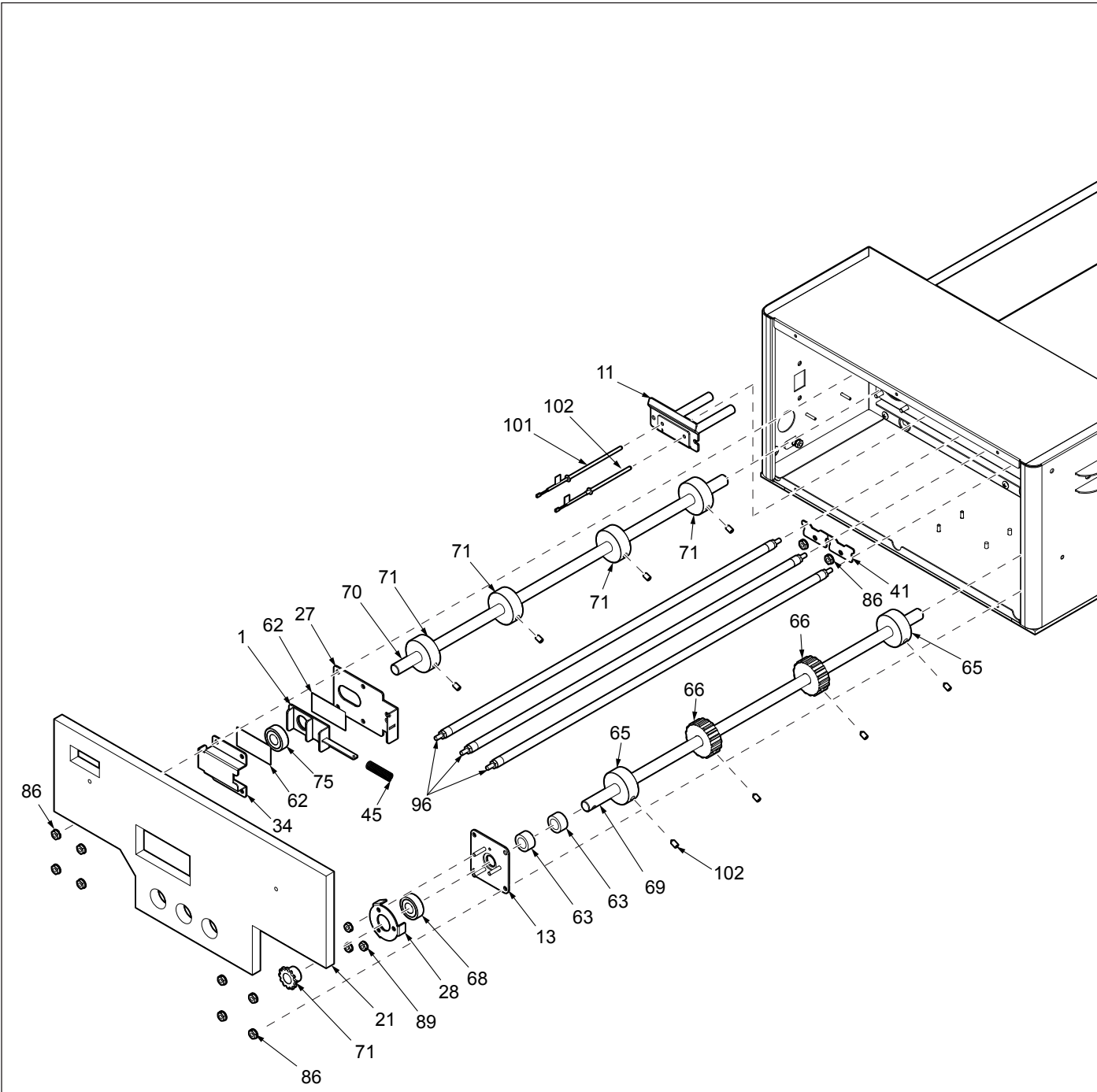

REPLACEMENT PARTS (continued)

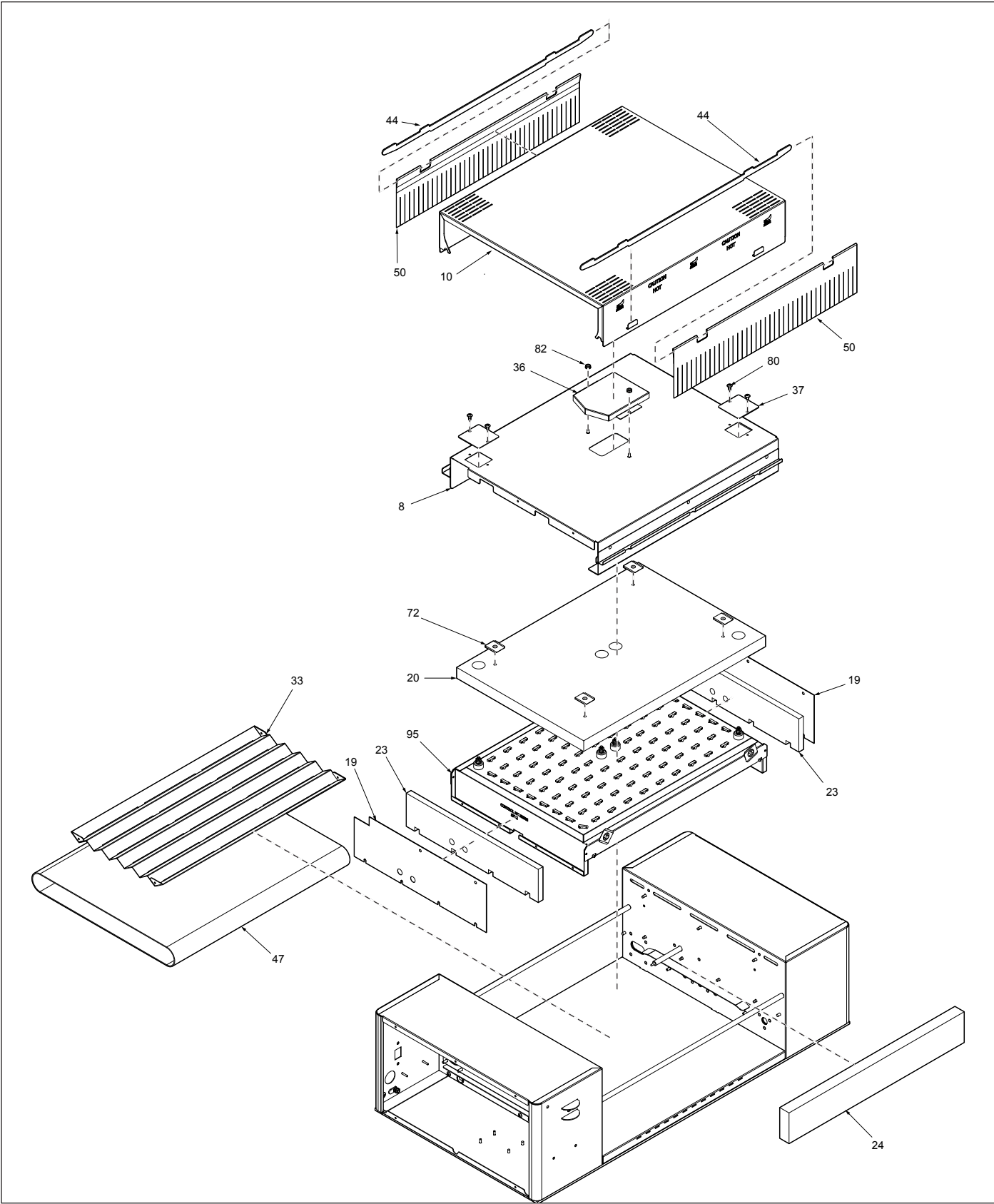

REPLACEMENT PARTS (continued)

Item	Part No.	Description	Qty.
1	0021482	Bearing Bracket/Clip Weldment	2
2	0022028	Control Housing Cover Weldment	1
3	0022029	Control Housing Weldment	1
4	0022030	End Housing Weldment	1
5	0022031	End Housing Cover Weldment	1
6	0022032	Bun Feeder Weldment	1
7	0022041	Tray Holder Weldment	1
8	0022042	Top Inside Cover Weldment	1
9	0022050	Relay Mount Bracket Weldment	1
10	0022051	Top Cover Weldment	1
11	0022052	Weldment, Probe Bracket, Ctl Hsg.	1
12	0022053	Weldment, Thermocouple Bracket, End Hsg.	1
13	0022054	Front Bearing Plate Weldment	1
14	0200329	Base Gasket, 33.86" LG	2
15	0200333	Base Gasket, 14.60" LG	2
16	0400119	Bushing, Shorty 5/8"	4
17	0400448	Nomex Insulation, Control Hsg.	1
18	0400449	Mica Insulation, Probe Assembly	2
19	0400450	Mica Insulation, Heater Sides	2
20	0400451	Insulation, Heater Top	1
21	0400452	Insulation, Control Hsg.	1
22	0400453	Insulation, End Hsg.	1
23	0400454	Insulation, Heater Side	2
24	0400455	Insulation, Side	1
25	0400456	Insulation, Base	1
26	0503376	Retainer, Bearing	1
27	0504304	Plate, Spacer	2
28	0506067	Retainer, Bearing	1
29	0506895	Bracket, Base Insulation Retainer	1
30	0506896	Base	1
31	0506897	Cover, Bottom	1
32	0506904	Bracket, Belt Guide Rh	2
33	0506907	Reflector, Bottom	1
34	0506908	Bracket, Tensioner	2
35	0506909	Tray, Crumb	1
36	0506929	Cover, Terminal	1
37	0506930	Guard, Terminal	2
38	0506946	Bracket, Motor Mounting	1
39	0506961	Plate, Motor Mounting	1
40	0506963	Reflector, Inside Wall	1
41	0506964	Clip, Heater	4
42	0507073	Bracket, USB Mounting	1
43	0507194	Cover, USB	1
44	7001030	Curtain Retainer Kit (incl. 2 retainers)	1
45	0600141	Spring, Compression	2
46	0700915	Wire Set, Horz. IR Toaster	1
47	0800384	Belt Wire Flat - Flax	1
48	0800386	Link Set, Wire Belt	1
49	0800470	Rod, Support, 19.875" LG	2
50	7001029	Curtain Kit (incl. 2 curtains)	1

Item	Part No.	Description	Qty.
51	1000900	Label - Warning	1
52	1001213	Label - Shock Hazard	1
53	1001569	Label, Control	1
54	1001571	Label, Muffin - Bagel, Power	1
55	1001572	Label, Muffin - Bagel	1
56	1001574	Wiring Diagram	1
57	21000-0043	Spacer, 3/8 CBS Thread Female	2
58	21000-0046	Standoff, 1/4" Locking PCB	4
59	21000-0050	Spacer, 8 Mm Dia X 6Mm Long Nylon 6/6	5
60	2100212	Handle, Pocket Pull, Snap-In	1
61	2100256	Thrust Strip, Teflon	1
62	2100334	Thrust Strip, Teflon	4
63	2120107	Spacer, Aluminum	2
64	2140109	Loctite # 242 (Blue)	1
65	2150254	Roller	2
66	2150277	Sprocket, Drive 17 Tooth	2
67	2150316	Sprocket, 25B12 3/8" Bore	1
68	2150384	Bearing Assy, Hi-Temp 1 1/8" Od X 1/2" Id	3
69	2150388	Drive Shaft	1
70	2150389	Idler Shaft	1
71	2150392	Sprocket, 25B12 1/2" Bore	1
72	300P117*	Washer, Retainer	1
73	304P105*	Nut, Hex 'Keps' #4-40	1
74	304P114*	Screw, Mach #4-40 X 1/4"	1
75	304P117*	Hex Spacer, Male-Female 4-40 X 3/4"Lg	1
76	306P104*	Screw, Mach. #6-32 X 1/4"	1
77	306P130*	Nut, Hex Keps #6-32 (Small Pattern)	1
78	308P124*	Screw, Mach One-Way #8-32	1
79	308P143*	Nut, Hex 'Keps' #8-32	1
80	308P157*	Screw, Tap 8-32 X 3/8"Lg	1
81	308P183*	Screw, Hex Head 'Sems' # 8-32 X 0.375	1
82	308P199*	Nut, Hex 'Keps' #8-32	1
83	308P203*	Screw, Tap 8-32 X 3/8" W/Int. Tooth Washer	1
84	308P227*	Scr Mach #8-32 X 3/8" HXHDSLTD; Shoulder	1
85	310P109*	Screw, Mach. #10-32 X 3/8"	1
86	310P146*	Nut, Hex 'Keps' #10-32	1
87	310P187*	Screw Set, #10-32 X 3/8 Hex Socket-Cone Point	1
88	310P199*	Scr, #10-32 X 3/8 Lg Socket Hd Cap	1
89	310P213*	Screw, PHPNHD #10-16 X 3/4" Thrd Form	1
90	4000132	Fan, Blower	1
91	4000202	Fan, Axial - 230V, Metal Housing & Imp1	1
92	4000208	Gearmotor, 1/75Th Hp, 230V	1
93	4010187	Transformer, 240 VAC/12VAC	1
94	4030352	Thermostat, Hi-Limit 700°F	1

REPLACEMENT PARTS (continued)

Item	Part No.	Description	Qty.
95	4030441	Top Heater, 4.1 Kw, 208 Vac	1
96	4030444	Heating Element 800W/208V	3
97	4050180	Heat Sink	2
98	4050236	Contactora, 2 Pole No	1
99	4050240	Relay, Solid State Dual Pole W/Conn-Recept	1
100	4051010	Relay, Random Phase, Solid State-50A1	1
101	4051025	Thermocouple Type "K"	1
102	4051026	Thermocouple Type "K"	1
103	4051027	Thermocouple Type "K"	1
104	4060374	Ground Lug	1
105	4060451	USB, A-F Pnl Mount/A-M Shield	1
106	4060453	Serial Ribbon Cable	1
107	4060464	Cable Tie, Reuseable, W/ Mouting Strap	1
108	4070194	Display Board	1
109	4070196	Motor Board	1
110	4070198	Snubber Board	1
111	4070206	Muffin / Bagel / Power, Board	1
112	4070208	Assy, PCB Board, Input Select	1
113	4070216	Assembly, PCB - Current Sense Board	1
114	4070221	Varistor Board	1
115	4070223	Assy-PCB, Mcd Horz Toast Main Board	1
116	Ter68-0001	Terminal-Tab Adapter .250" X .032"	1
117	0013029	Conveyor Housing Assembly	1
118	0013030	Control Housing Cover Assembly	1
119	0013031	End Housing Cover Assembly	1
120	0013032	Top Cover Assembly	1
121	0013040	Control Housing Probe Assembly	1
122	0013050	End Housing Probe Assembly	1
123	0013051	Drive Shaft Assembly	1
124	0013052	Idler Shaft Assembly	1
125	0013053	Relay - Sink Bracket Assembly	1
*Available in packages of 10 (ten)			

WIRING DIAGRAM

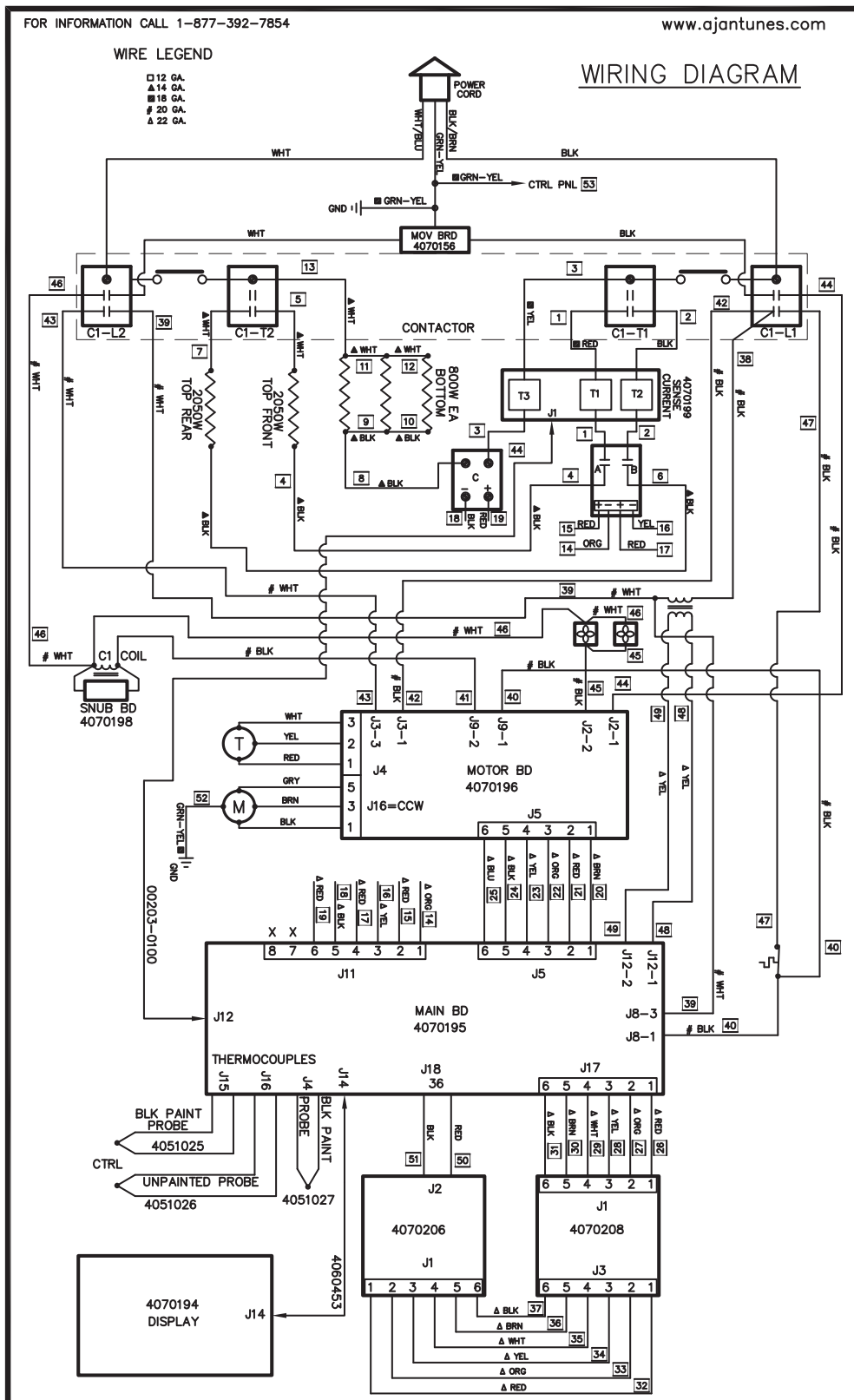



A.J. Antunes & Co.

We exist to make our customers successful.

A.J. Antunes & Co.
Headquarters/Manufacturing
Carol Stream, Illinois 60188 USA
Phone: (630) 784-1000
Toll Free: (800) 253-2991
Fax: (630) 784-1650

Antunes Equipment
Manufacturing (Suzhou) Ltd.,
Suzhou, Jiangsu, China 215011
Phone: 86-512-6841-3637
Toll Free: 400-0-7878-22
Fax: 86-512-6841-3907

www.ajantunes.com