

Place this manual in the Toaster section
of your Equipment Manual.
Manufactured exclusively for
McDONALD'S®

BY
A.J. ANTUNES & CO.
180 KEHOE BLVD.
CAROL STREAM, ILLINOIS 60188, U.S.A.
PHONE: 1-630-784-1000
TOLL FREE: 1-877-392-7854
FAX: 1-630-784-1650
www.ajantunes.com



A.J. Antunes & Co.



HCT-5H & HRT-5H

Scan with mobile device or enter URL
for product and service information.

<http://tiny.cc/ajaHCT-HRT>

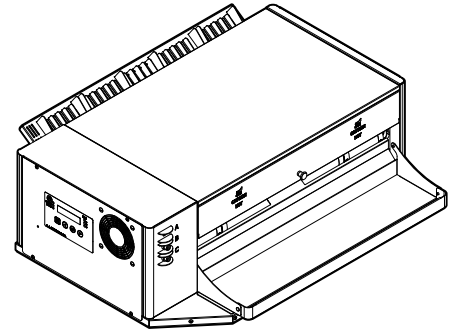

TABLE OF CONTENTS

Owner Information	2	Adjusting Toast Quality	6
General	2	Language Selection	6
Service/Technical Assistance	2	Programming	7
Warranty Information	2	Control Panel	7
Specifications	3	Settings	7
Electrical Specifications & Plug Configuration	3	Purging Product from Toaster	7
Pass Through Time	3	Factory Reset	7
Dimensions	3	Maintenance	8
Important Safety Information	4	Daily Cleaning	8
Installation	5	Quarterly Maintenance	9
Unpacking	5	Troubleshooting	12
Location	5	Replacement Parts	16
Operation	6	Wiring Diagram	21
Operating Instructions	6	Notes	22

LIMITED WARRANTY

The Antunes Food Service Equipment Division of A.J. Antunes & Co. provides the following limited warranty to the original purchaser of all McDonald's Equipment. All components are warranted against defects in the material and workmanship for a period of two (2) years from date of original installation.

If any part becomes defective during the period of this Warranty, Antunes Food Service will pay labor costs to an Authorized Service Agent to replace the part plus travel expenses.

WARRANTY EXCLUSIONS

- The cost of Installation.
- Equipment that has been damaged due to shipment. Purchaser should make damage claim directly upon carrier.
- Alteration, misuse, abuse.
- Improper storage or handling.
- Improper maintenance.
- Failure to follow proper Installation instructions, including electrical connection.

- Improper or unauthorized repairs.
- Scheduled Maintenance procedures as outlined in your MRC Card.
- This Warranty does not cover Consumable items. **NOTE: The Conveyor Belt wraps are consumable items that can be easily adjusted or replaced according to the Maintenance Section of this product's Owner's Manual.**
- Water pressure problems or contamination problems such as foreign material in water lines or inside solenoid valves due to an incoming water source.
- Freight, foreign, excise, municipal or other sales or use taxes.
- Consequential damages such as loss of profit, loss of time, the cost of repairing or replacing other property which is damaged, or any other incidental damage of any kind.

Antunes Food Service reserves the right to make changes in design or add improvements on any products. The right is always reserved to modify Equipment because of factors beyond our control and government regulation. Changes to Equipment do not constitute a warranty charge. This warranty is exclusive and is in lieu of all other warranties, expressed or implied, including any implied warranty of merchantability or fitness for a particular purpose, each of which is expressly disclaimed. The remedies described above are exclusive, and in no event shall A.J. Antunes & Co. or any of its Divisions be liable for special consequential or incidental damages for the breach or delay in the performance of this warranty.

This manual is for the exclusive use of licensees and employees of McDonald's Systems, Inc..
© McDonald's Corporation All Rights Reserved

OWNER INFORMATION

General

This manual provides the safety, installation, and operating procedures for this unit. Please read this manual prior to installing and operating the unit.

This unit is manufactured from the finest materials available and assembled to Roundup's strict quality standards. This unit has been tested at the factory to ensure dependable trouble-free operation.

Service/Technical Assistance

If you experience any problems with the installation or operation of your unit, contact your Authorized Service Agency.

Warranty Information

Please read the full text of the Limited Warranty in this manual.

If the unit arrives damaged, contact the carrier immediately and file a damage claim with them. Save all packing materials when filing a claim. Freight damage claims are the responsibility of the purchaser and are not covered under warranty.

The warranty does NOT extend to:

- Damages caused in shipment or damage as result of improper use.
- Installation of electrical service.
- Normal maintenance as outlined in this manual.
- Malfunction resulting from improper maintenance.
- Damage caused by abuse or careless handling.
- Damage from moisture into electrical components.
- Damage from tampering with, removal of, or changing any preset control or safety device.

Fill in the information below and have it handy when calling your Authorized Service Agency for assistance. The serial number is on the specification plate located on the rear of the unit.

Purchased From: _____

Date of Purchase: _____

Model No.: _____

Serial No.: _____

Mfg. No.: _____

Network ID Number: _____

Refer to the service agency directory packaged with your manual and fill in the information below:

Authorized Service Agency

Name: _____

Phone No.: _____

Address: _____

Use only genuine Roundup replacement parts in this unit. Use of replacement parts other than those supplied by the manufacturer will void the warranty. Your Authorized Service Agency has been factory trained and has a complete supply of parts for this toaster.

You may also contact the factory at 1-877-392-7854 (North America only), or 630-784-1000 if you have trouble locating your local Authorized Service Agency.

IMPORTANT! Keep these instructions for future reference. If the unit changes ownership, be sure this manual accompanies the equipment.

SPECIFICATIONS

Electrical Specifications & Plug Configuration

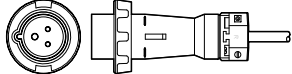
Model & Mfg. No	Volt	Watts	Hz.	Plug Description	Plug Configuration
HCT-5H (Domestic) 9210850	208	4430-5250	60	Pin & Sleeve Plug 30 Amps, 250 VAC	

Pass Through Time

For all HCT-5H units the pass through time is 22 seconds (+/- 2 seconds).

⚠ CAUTION ⚠

All electrical connections must be in accordance with local electrical codes and any other applicable codes.

Dimensions

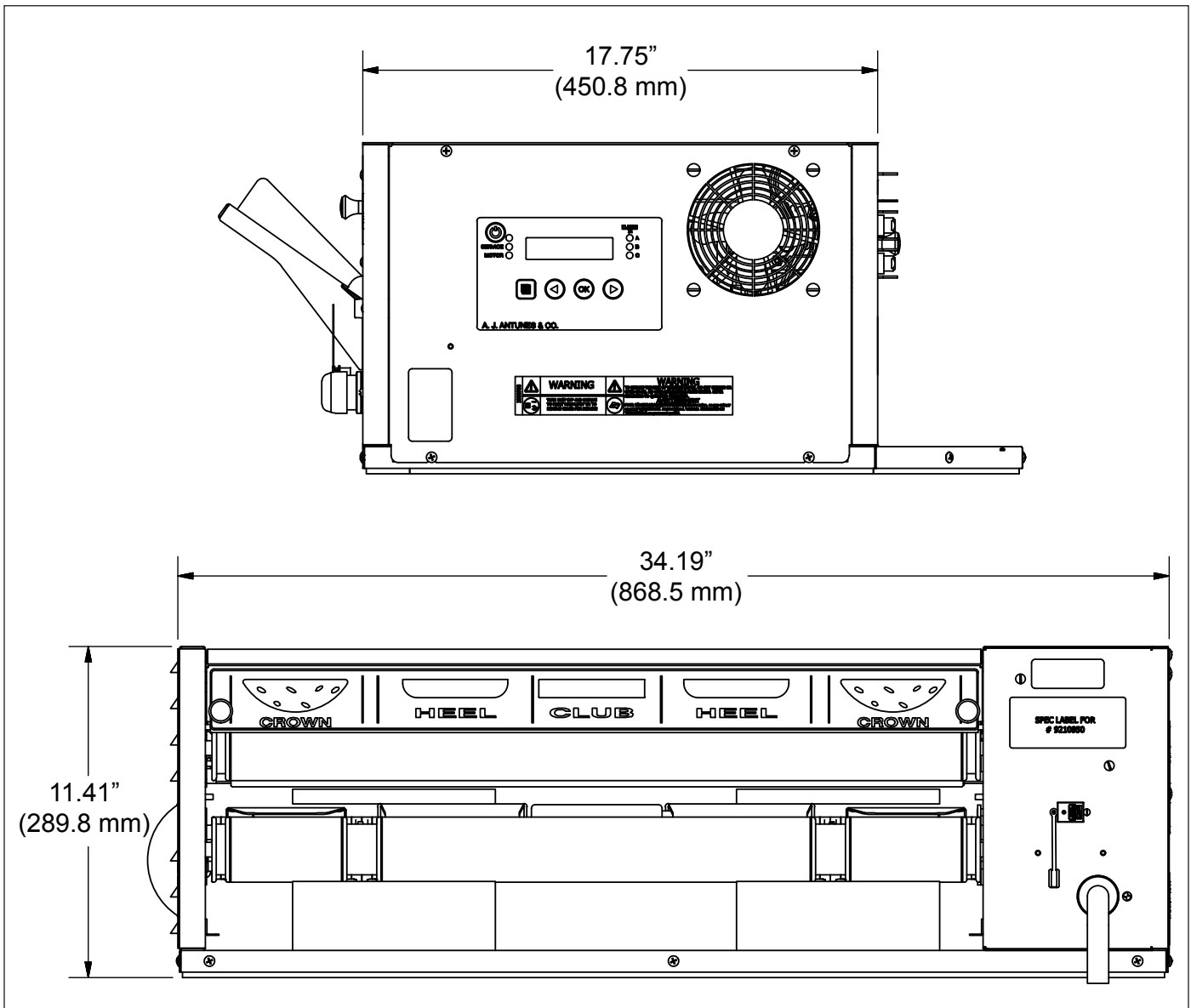

IMPORTANT SAFETY INFORMATION

In addition to the warnings and cautions in this manual, use the following guidelines for safe operation of the unit.

- Read all instructions before using equipment.
- For your safety, the equipment is furnished with a properly grounded cord connector. Do NOT attempt to defeat the grounded connector.
- Install or locate the equipment only for its intended use as described in this manual. Do NOT use corrosive chemicals in and/or on this equipment.
- Do NOT operate this equipment if it has a damaged cord or plug, if it is not working properly, or if it has been damaged or dropped.
- This equipment should be serviced by qualified personnel only. Contact the nearest Authorized Service Agency for adjustment or repair.
- Do NOT block or cover any openings on the unit.
- Do NOT immerse cord or plug in water.
- Keep cord away from heated surfaces.
- Do NOT allow cord to hang over edge of table or counter.
- Do NOT clean this appliance with a water jet.

The following warnings and cautions appear throughout this manual and should be carefully observed.

- Turn the unit off, wait for the cool-down procedure to complete its cycle, and disconnect the power cord before performing any service or maintenance on the unit.

NOTE: Turning off the power switch does NOT turn off all power to the unit. When the unit is plugged in and turned off, an LED light flashes to indicate that the power cord is plugged in.

WARNING

To avoid possible personal injury and/or damage to the unit, all inspections, tests, and repair of electrical equipment should be performed by **QUALIFIED SERVICE PERSONNEL**. The unit **MUST be completely shut down and unplugged** before any internal servicing, except when electrical tests are required. Use extreme care during electrical circuit tests. Live circuits will be exposed.

CAUTION

All electrical connections must be in accordance with local electrical codes and any other applicable codes.

CAUTION

Bread may burn. Therefore toasters must not be used near or below curtains or other combustible walls and materials. Failure to maintain safe operating distances may cause discoloration or combustion.

CAUTION

NEVER unplug the power cord while the unit is running! Use the proper shutdown procedure before unplugging the power cord.

WARNING

ELECTRICAL SHOCK HAZARD. FAILURE TO FOLLOW THE INSTRUCTIONS IN THIS MANUAL COULD RESULT IN SERIOUS INJURY OR DEATH.

- Electrical ground is required on this appliance.
- Do NOT modify the power supply cord plug. If it does not fit the outlet, have a proper outlet installed by a qualified electrician.
- Do NOT use an extension cord with this appliance.
- The toaster should be grounded according to local electrical codes to prevent the possibility of electrical shock. It requires a grounded receptacle with separate electrical lines, protected by fuses or circuit breaker of the proper rating.
- Check with a qualified electrician if you are unsure if the appliance is properly grounded.

INSTALLATION

Unpacking

1. Open the large box. It contains:
 - HCT-5H toaster
 - Accessories box
2. Remove the accessories box from the large box.
3. With the help of another person, carefully remove the HCT-5H from the large box.
4. Remove all protective coverings from the unit.
5. Open the Accessories Box. It contains:
 - Owner's Manual
 - Bun Feeder
 - Bun Buffer Frame
6. Wipe the entire exterior of the toaster and the accessories mentioned above with a clean towel sprayed with a McDonald's approved sanitizer. Allow to air dry.

NOTE: Handle accessories with care. If an accessory becomes bent or damaged, it may not attach to the unit correctly, which may affect normal operation.

NOTE: If any parts are missing or damaged, contact A.J. Antunes Technical Service IMMEDIATELY at 1-877-392-7854 (North America only), or 630-784-1000.

Location

When placing the toaster into service, pay attention to the following guidelines:

- Make sure power is off and the toaster is at room temperature.
 - Do NOT block or cover any openings on the unit.
 - Do NOT immerse cord or plug in water.
 - Keep cord away from heated surfaces.
 - Do NOT allow cord to hang over edge of table or counter.
1. Place the toaster in the required position designated by McDonald's.

NOTE: The HCT-5H is designed to be used with the HRT-5H toaster. When installed together, the HRT-5H should be placed on top of the HCT-5H.

2. Attach the Bun Feeder, Crumb Tray, and Bun Buffer Frame (Figure 1).
3. Plug the power cord into an appropriate power outlet.

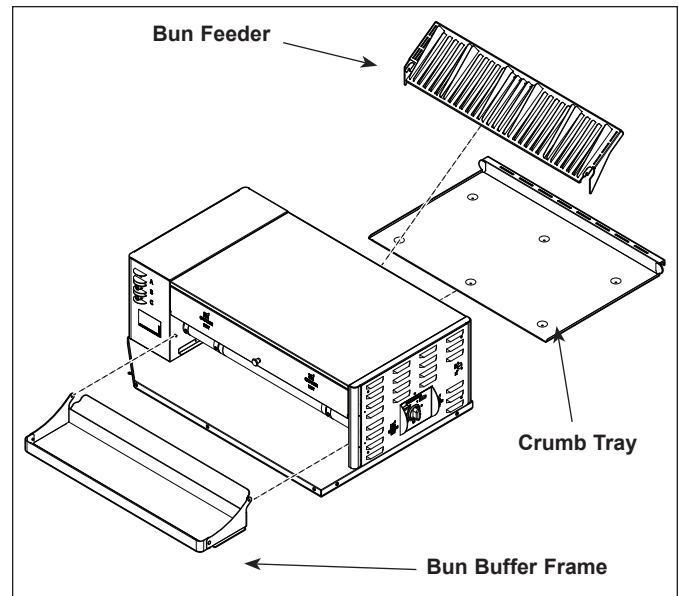

Figure 1. HCT-5H Components

OPERATION

Operating Instructions

Follow these steps to start the toaster:

1. Plug in the power cord. Press and release the Power Button to turn on. Wait until the Control Panel displays "Ready".
2. Set the Compression Knob to 4 (recommended).
3. Insert product into the designated area of the Bun Feeder with the cut side of the bun facing down. Toasted product drops into the Bun Buffer.

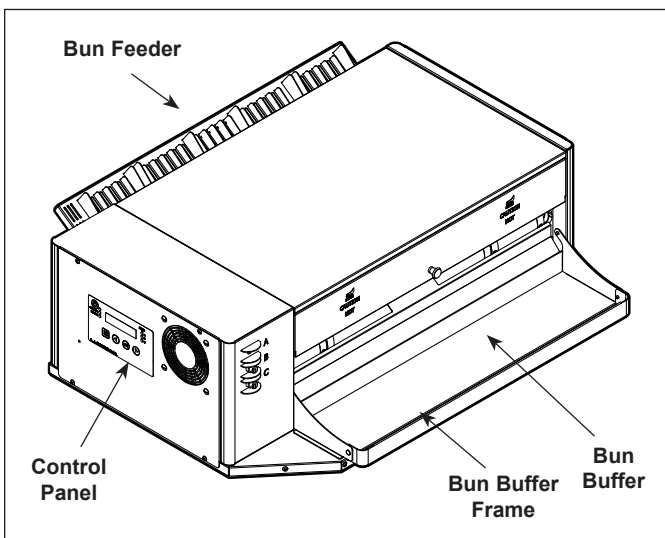

Figure 2. HCT-5H

Adjusting Toast Quality

There are variations in bun products that are used on the A.J Antunes HCT-5H toaster such as moisture content, bun formulations, age, tolerances etc. The HCT-5H was designed to compensate for bun variations by allowing user to adjust the compression, light/dark (speed) & temperatures settings in order to achieve a Gold Standard toasted product.

1. LIGHT DARK ADJUSTMENT: Adjust the light dark setting with the < > buttons. The default light/dark setting on the HCT-5H from the factory is 0 but can be adjusted from Lighter (0-10) to Darker (0-10). Light 10 is the lightest setting and dark 10 is the darkest. Each increase in "lighter" value will increase the pass through time and each increase in "darker" value will decrease the pass through time.

Language Selection

Follow these steps to set the language option for the toaster.

1. Plug in the power cord and turn the toaster on.
2. See Figure 3. Press and hold the **MENU** button for five seconds.
3. Press ◀ until the display shows "English".
4. Press **OK**.
5. Press ◀ or ▶ to select your preferred language. The available languages appear in the following order:
 - English
 - Spanish
 - French Canadian
6. Press the OK button to save the changes.
7. Return the toaster to service.

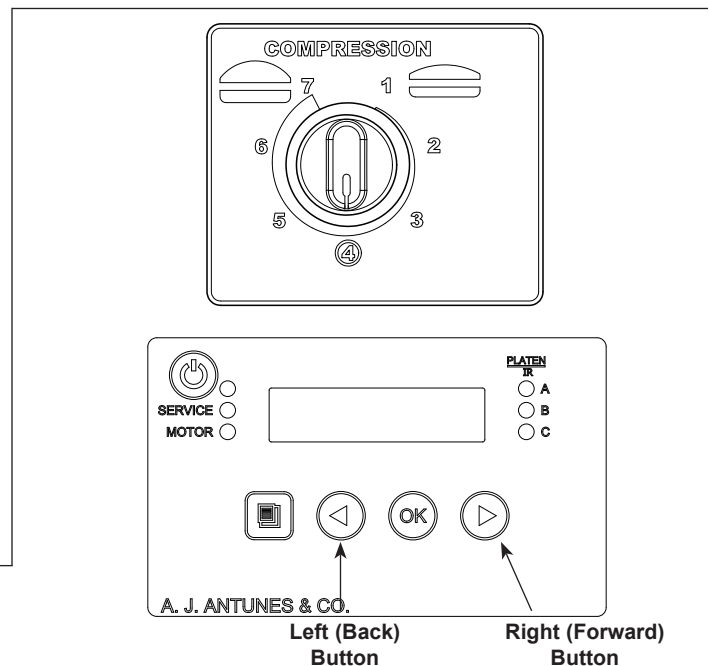

2. TEMPERATURE ADJUSTMENT: Adjust the set point temperature on the platens in the program menu. The default temperature settings on the HCT-5H are A Platen: 282°C (540°F) B Platen: 282°C (540°F) C Platen: 254°C (490°F). The temperatures can be increased to +/- 50°F (10°C) if needed to achieve an acceptable toast quality.

3. COMPRESSION ADJUSTMENT: Adjust the compression knob on the side of the unit. The default compression setting on the HCT-5H is 4 but is adjustable from 1-7. It is acceptable to adjust the compression from 1-7 as needed to achieve the desired toast quality and bun compression.

PROGRAMMING

Control Panel

Access the Control Panel by facing the front of the unit and moving to the left side of the unit. The LEDs on the control panel light to signify when each item is operating. The Service LED lights and the corresponding LED blinks when the unit requires service. A message also appears on the display.

Settings

Follow the steps below to view and adjust settings.

1. When the unit is plugged in, press and hold the **MENU** button (Figure 4) for five seconds. The control panel displays "Platen A"

NOTE: The unit does not have to be turned on in order to access the settings menu.

2. Press ◀ and ▶ (Figure 4) to scroll through the settings, which appear in the following order:
 - Platen A
 - Platen B
 - Platen C
 - Units (°C/°F)
 - Buzzer (On/Off)
 - Language
 - Service Messages
 - Controls Temperature
 - Motor (view only)
 - Conveyor (view only)
3. To change a setting, press the **OK** button and then press ◀ and ▶ to adjust as needed. Press the **OK** button again to save the changes. See Figure 3.

NOTE: The Elapsed Time and Control Temperature can not be adjusted.

The table below describe platen and motor settings depending on the Compression Knob setting:

When using recommended Compression Setting of #4
A Platen: 540° F (282° C)
B Platen: 540° F (282° C)
C Platen: 490° F (254° C)
Conveyor Speed: 22.0 seconds

Table 1. Temperature/Compression Settings

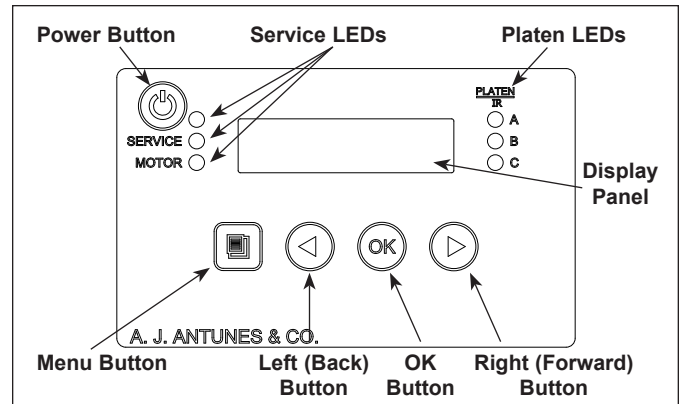

Figure 3. HCT-5H Control Panel

Factory Reset

To reset the unit to the factory default settings:

1. Turn the unit off
2. Press and hold ◀ and ▶ and turn the unit on.
3. The toaster displays "Factory Settings Restored" on the display.

NOTE: For ALL Units, this sets the display temperature to °F (Fahrenheit). Refer to the "Settings" section of this manual to change the display temperature to °C (Celsius).

Purging Product from Toaster

To purge product from the toaster, press and hold ◀ and ▶ together. This speeds up the conveyors to force product out of the front of the toaster.

MAINTENANCE

Daily Cleaning

CLEAN AND SANITIZE TOASTER AND BELTS (DAILY)

1. Press and release the Power Button to turn the toaster off. The toaster enters a cool-down mode and automatically shuts down when complete.

NOTE: You do NOT need to wait for the cool down to complete.

2. Put on neoprene gloves. Remove the Bun Feeder, Crumb Tray, and Bun Buffer Frame (Figure 4).
3. Clean the outside surfaces of the toaster with a paper towel sprayed with an approved multi-surface cleaner. Allow to air dry.
4. Wash the Bun Feeder, Crumb Tray, and Bun Buffer Frame at the three-compartment sink. Allow to air dry.
5. Reattach the Bun Feeder, Crumb Tray, and Bun Buffer Frame.
6. Plug the power cord into the appropriate outlet. Press and release the Power Button to turn the unit on. Return to normal operation.
7. Lift the front door to inspect the belts (Figure 4). Replace any Belts that are torn, folded, discolored, missing snaps, or damaged in any way.

NOTE: The conveyors continue to turn during the cool-down period, allowing you to clean the entire Belt.

8. If the Belts are all in good condition, spray a clean, sanitized towel with an approved multi-surface cleaner. Wipe all of the Belts clean for two revolutions of the belts.

NOTE: You may need to wipe the Belts more two rotations.

8. Next, spray a clean, sanitized towel with an approved sanitizer. Wipe both Belts for two revolutions.
7. Re-install the Bun Feeder, Crumb Tray, and Bun Buffer Frame.
8. Press and release the Power Button to turn the toaster on. Return to normal operation.

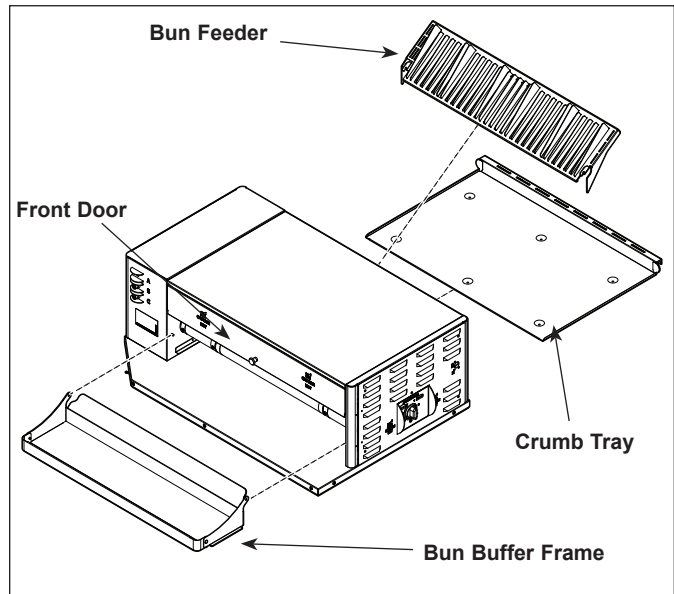

Figure 4. HCT-5H Components

NOTE: Be sure to clean and sanitize the Belts completely. Improper cleaning shortens the life of the Belts and results in poor toaster performance.

NOTE: Replace any Belts that show excessive wear and tear. To obtain new Belts, contact your Distribution Center (DC).

NOTE: Belts should be removed ONLY during Belt replacement or when required in a service situation.

NOTE: We recommend that Belts be replaced every quarter.

MAINTENANCE (continued)

Quarterly Maintenance

NOTE: The Belt Wraps are considered a consumable item that can be easily maintained and replaced according to these instructions.

Quarterly Maintenance includes all daily maintenance as well as the replacement of belt wraps.

Over time, the Belts will begin to show signs of wear. This wear appears in the form of tears or discoloration of the belt, at which point the belts should be replaced.

NOTE: Belts should be removed **ONLY** during Belt Replacement or when required in a service situation.

NOTE: We recommend that Belts be replaced every quarter.

INSPECTING BELTS

Inspect all belt wraps daily for signs of tearing, folding, or any damage. Replace any damaged belts as needed.

Refer to the images on this page for examples of belt damage that requires belt replacement.



BELT IS MISSING SNAPS AND IS DAMAGED. REPLACE BELT.

Figure 7. Example of Damaged Belt

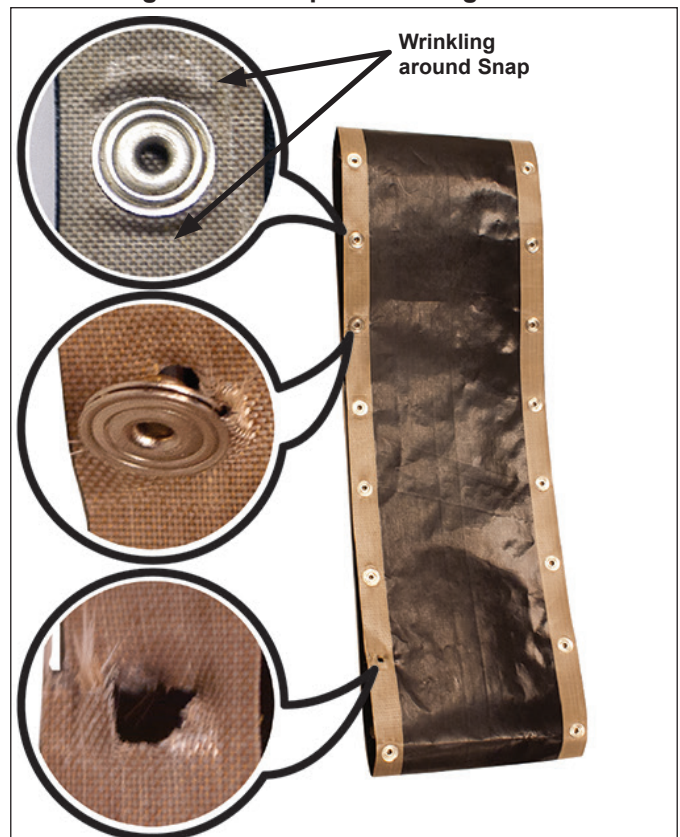

BELT IS WRINKLING/DISTRESSED AROUND SNAPS, HAS LOOSE/DAMAGED SNAPS, AND IS MISSING SNAPS. REPLACE DEFECTIVE BELT.

Figure 8. Example of Damaged Belt

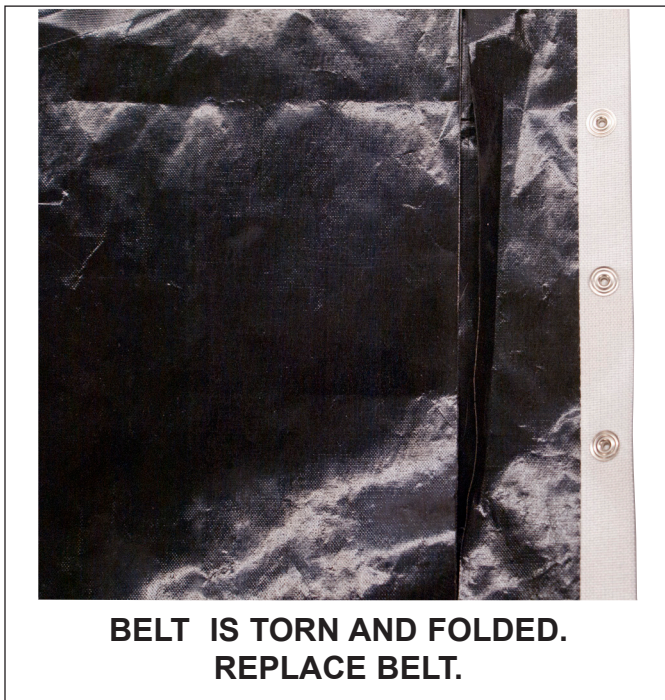

BELT IS TORN AND FOLDED. REPLACE BELT.

Figure 6. Example of Damaged Belt

MAINTENANCE (continued)

REMOVING BELTS

1. Turn the toaster off. The toaster enters a cool-down mode and automatically shuts down when complete.
2. Unplug the power cord once the cool-down period is complete.
3. Put on neoprene gloves. Remove the Bun Feeder, Crumb Tray, and Bun Buffer Frame.
4. Set the Compression Knob to 7.
5. Unlock the latch on the non-control side of the toaster. Open the side panel.
6. Refer to Figure 5. Lift the latch just above the Bun Compression Knob and then open the Belt Frame Lock as shown.
7. Push the Top Roller in towards the toaster so the roller slides DOWN and locks into place.
8. Push the Bottom Roller in towards the toaster so the roller slides DOWN and locks into place.
9. Remove and discard the Top Belt (the recommendation is to cut it in half so it cannot be used again).
10. Remove and discard the Bottom Belts (the recommendation is to cut them in half so they cannot be used again).
11. **CLEAN ROLLERS:** Wipe all four rollers with a clean towel sprayed with sanitizer. Make sure to remove all debris from the rollers so they are as clean as possible.

NOTE: It is VERY important to clean all four rollers whenever the belts are removed or replaced.

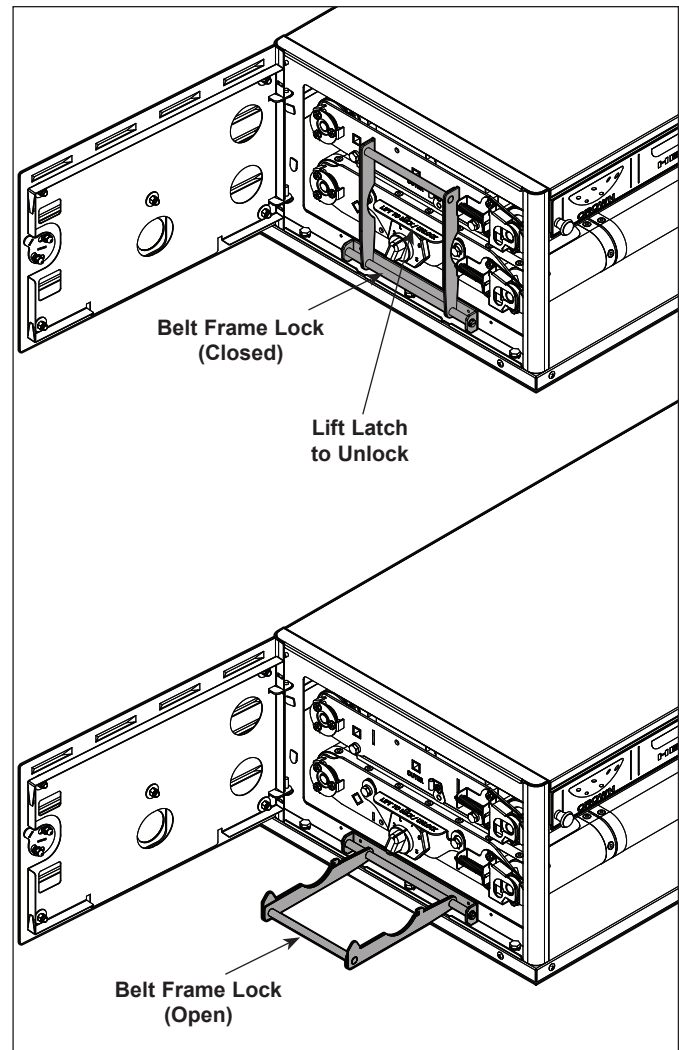

Figure 5. Belt Frame Lock

MAINTENANCE (continued)

INSTALLING BELTS

1. Follow the steps for *Removing Belts*.
2. Wipe both sides of the new Belts with a clean, sanitized towel sprayed with an approved sanitizer and allow to air dry.
3. **CLEAN ROLLERS:** Wipe all four rollers with a clean towel sprayed with sanitizer. Make sure to remove all debris from the rollers so they are as clean as possible.

NOTE: It is VERY important to clean all four rollers whenever the belts are removed or replaced.

4. Slide the new Top Belt gently over the top rollers.

NOTE: Make sure the belt lines up properly on the rollers. The snaps on the belts should face the inside of the top rollers.

5. Slide the first crown belt over the rear top roller and rear bottom roller. Repeat this step for the club/ heel belt and the second crown belt.

NOTE: Make sure the belt lines up properly on the rollers. The snaps on the belts should face the inside of the bottom rollers.

6. Return the Top and Bottom Belt Rollers to full tension:
 - Pull the Top Roller UP so it can slide out towards the front of the toaster into operating position.
 - Push the Bottom Roller UP so it can slide out towards the front of the toaster into operating position.
7. Close the Belt Frame Lock firmly into place (Figure 5) and press the latch in Figure 5 down.
8. Close and latch the Side Panel.

NOTE: Inform the Store Manager after any Belt Replacement so new Belts can be ordered.

9. Set the Compression Knob to 4.
10. Re-install the Bun Feeder, Crumb Tray, and Bun Buffer Frame.
11. Plug the power cord into the appropriate outlet. Turn the toaster on.

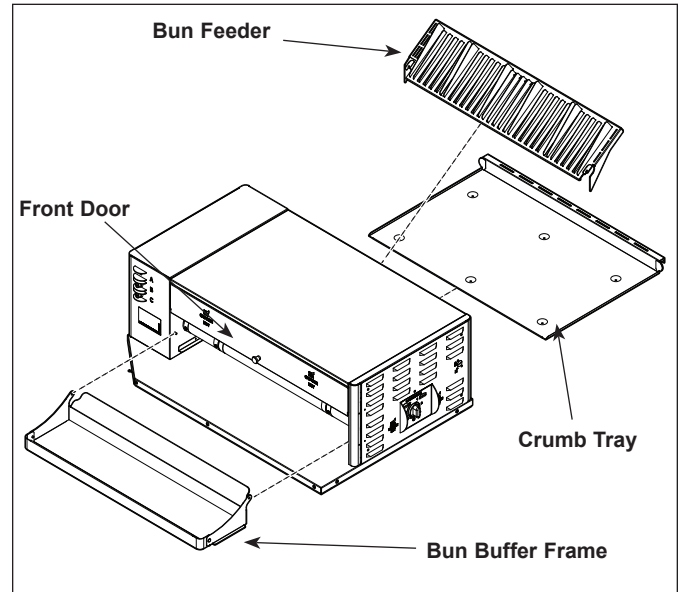

Figure 4. HCT-5H Components

TROUBLESHOOTING

⚠️ WARNING ⚠️

To avoid possible personal injury and/or damage to the unit, inspection, test and repair of electrical equipment should be performed by qualified service personnel. The unit should be unplugged when servicing, except when electrical tests are required.

If the troubleshooting steps listed do not solve your machine problem, contact an Authorized Service Agency for further assistance or service.

Problem	Possible Cause(s)	Corrective Action
Display Reads "Hi-Limit Tripped"	Either Hi-Limit A or B has tripped.	Remove black cap & firmly press the green buttons. Contact AJA Technical Support 877-392-7854 for assistance.
Display Reads "Conveyor Stopped"	A Mechanical Obstruction has occurred which completely stalled the conveyor motor.	Check the conveyor belts & surrounding areas for any obstructions/jams. Call AJA Technical Support 877-392-7854 for assistance.
Display Reads "Motor Running Slow"	A Mechanical Obstruction has occurred that is slowing down the conveyor motor.	
Display Reads "Motor Slow"		
Display Reads "Motor Load"		
Display Reads "Control Temperature Fail"	Toaster Electrical compartment is overheating due to Lack of airflow surrounding the toaster.	Inspect the cooling fan on the side for operation & ensure it is clean. Call AJA Technical Support 877-392-7854 for assistance.
Display Reads "Motor Temperature Fail"		
Display Reads "Internal Fault"	Control Board Malfunction.	Cycle Power OFF/ON. If message persists, then Call AJA Technical Support 877-392-7854 for assistance.
Display Reads "Internal Error"		
Display Reads "Overtemp A"	Platen A heater is overheating & exceeded its set-point.	
Display Reads "SSR A Fail"	The solid state relay for Platen A has failed.	
Display Reads "System A Fail"	The Platen Heater A heater did not reach set-point temperature.	
Display Reads "Platen A Low"	The Platen heater A heater has dropped below the set-point temperature after achieving set-point but cannot recover.	

TROUBLESHOOTING (continued)

Problem	Possible Cause(s)	Corrective Action
Display Reads "Heater A Fail"	The Platen Heater A heater did not reach set-point temperature.	Cycle Power OFF/ON. If message persists, then Call AJA Technical Support 877-392-7854 for assistance.
Display Reads "Sensor A Fail"	Platen Thermocouple A sensor has failed.	
Display Reads "Overtemp B"	Platen B heater is overheating & exceeded its set-point.	
Display Reads "SSR B Fail"	The solid state relay for Platen B has failed.	
Display Reads "System B Fail"	The Platen Heater B heater did not reach set-point temperature.	
Display Reads "Platen B Low"	The Platen heater B heater has dropped below the set-point temperature after achieving set-point but cannot recover.	
Display Reads "Heater B Fail"	The Platen Heater B heater did not reach set-point temperature.	
Display Reads "Sensor B Fail"	Platen Thermocouple B sensor has failed.	
Display Reads "Overtemp C"	Platen C heater is overheating & exceeded its set-point.	
Display Reads "SSR C Fail"	The solid state relay for Platen C has failed.	
Display Reads "System C Fail"	The Platen Heater C heater did not reach set-point temperature.	
Display Reads "Platen C Low"	The Platen heater C heater has dropped below the set-point temperature after achieving set-point but cannot recover.	
Display Reads "Heater C Fail"	The Platen Heater C heater did not reach set-point temperature.	
Display Reads "Sensor C Fail"	Platen Thermocouple C sensor has failed.	
Display Reads "USB Power"	An unauthorized device has been plugged into the rear USB Port that is over loading the USB port.	Remove the device from the port. NOTE: Only approved devices for special toaster software loading should be used. Call AJA Technical Support 877-392-7854 for assistance.

TROUBLESHOOTING (continued)

Problem	Possible Cause(s)	Corrective Action
No Display	Power Cord is not plugged into the outlet	Unplug the power cord then firmly plug back in
	No power at outlet	Contact your electrician
	Circuit Breaker is Tripped or OFF	Reset circuit breaker
	Equipment malfunction	Call AJA Technical Support 877-392-7854 for assistance
The buns must be forced into the toaster. Sticking and Burning	The upper &/or lower black belts are worn & need replacement	Replace all belts every 3 months as per PM
	The rear top &/or bottom spring loaded rollers are in the unlocked state.	Verify the roller is properly seated & extended towards the rear to apply tension to the belt. Call AJA Technical Support 877-392-7854 for assistance
	The black belts are worn due to not being properly cleaned daily or over 3 months old.	Follow the daily PM for the belts
	Improper compression setting	Use recommended compression #4. Call AJA Technical Support 877-392-7854 for assistance
	Mechanical problem within conveyor system	Call AJA Technical Support 877-392-7854 for assistance
Buns are toasting too light	Incorrect temperature set-points	Perform a factory reset as detailed in "Programming Section" of this owner's manual. Call AJA Technical Support 877-392-7854 for assistance
	Incorrect motor speed	Perform a factory reset as detailed in "Programming Section" of this owner's manual. Call AJA Technical Support 877-392-7854 for assistance
	Improper compression setting	Use recommended compression #4. Call AJA Technical Support 877-392-7854 for assistance
	The black belts are worn due to not being properly cleaned daily or are over 3 months old.	Follow the daily maintenance & quarterly belt replacement as detailed in the PM
	Light/Dark settings must be adjusted	Adjust the Light/Dark settings to achieve a darker product. Call AJA Technical Support 877-392-7854 for assistance
	Using refrigerated buns	Verify that only room temperature buns are being used
	The platen heater surface has carbon buildup	Clean any platen heater surface buildup. Call AJA Technical Support 877-392-7854 for assistance

TROUBLESHOOTING (continued)

Problem	Possible Cause(s)	Corrective Action
Buns are toasting too dark	Incorrect temperature set-points	Perform a factory reset as detailed in "Programming Section" of this owner's manual. Call AJA Technical Support 877-392-7854 for assistance
	Incorrect motor speed	Perform a factory reset as detailed in "Programming Section" of this owner's manual. Call AJA Technical Support 877-392-7854 for assistance
	Improper compression setting	Use recommended compression #4. Call AJA Technical Support 877-392-7854 for assistance
	The black belts are worn due to not being properly cleaned daily or are over 3 months old.	Follow the daily maintenance & quarterly belt replacement as detailed in the PM
	Light/Dark settings must be adjusted	Adjust the Light/Dark settings to achieve a lighter product. Call AJA Technical Support 877-392-7854 for assistance
The black belts appear too loose & sagging	The rear top &/or bottom spring loaded rollers are in the unlocked state.	Verify the roller is properly seated & extended towards the rear to apply tension to the belt. Call AJA Technical Support 877-392-7854 for assistance
The black belts are tearing prematurely	The 4 main rollers are not being cleaned of crumb/seeds buildup during belts during the quarterly belt replacement	Clean all 4 roller of any buildup until the roller surface feels smooth. Refer to the maintenance section of this owner's manual. Call AJA Technical Support 877-392-7854 for assistance
	The front bun landing tray is not properly secured or is damaged & impacting the belts	Re-secure the bun landing tray & adjusted as needed. Call AJA Technical Support 877-392-7854 for assistance
	The bun feeder is not properly secured or is damaged & impacting the belts	Re-secure the bun landing tray & adjusted as needed. Call AJA Technical Support 877-392-7854 for assistance
	Black belts were installed incorrectly	Verify the belts are properly installed & seated into place. Refer to the maintenance section of this owner's manual
Buns are being over compressed	Improper compression setting selected	Use recommended compression #4. Call AJA Technical Support 877-392-7854 for assistance
	The buns are not sliced to acceptable dimensions	Contact your bun supplier & have the buns inspected for proper dimensions
	Expired buns are being used	Use only buns that have not expired
	Mechanical problem within conveyor system	Call AJA Technical Support 877-392-7854 for assistance

REPLACEMENT PARTS

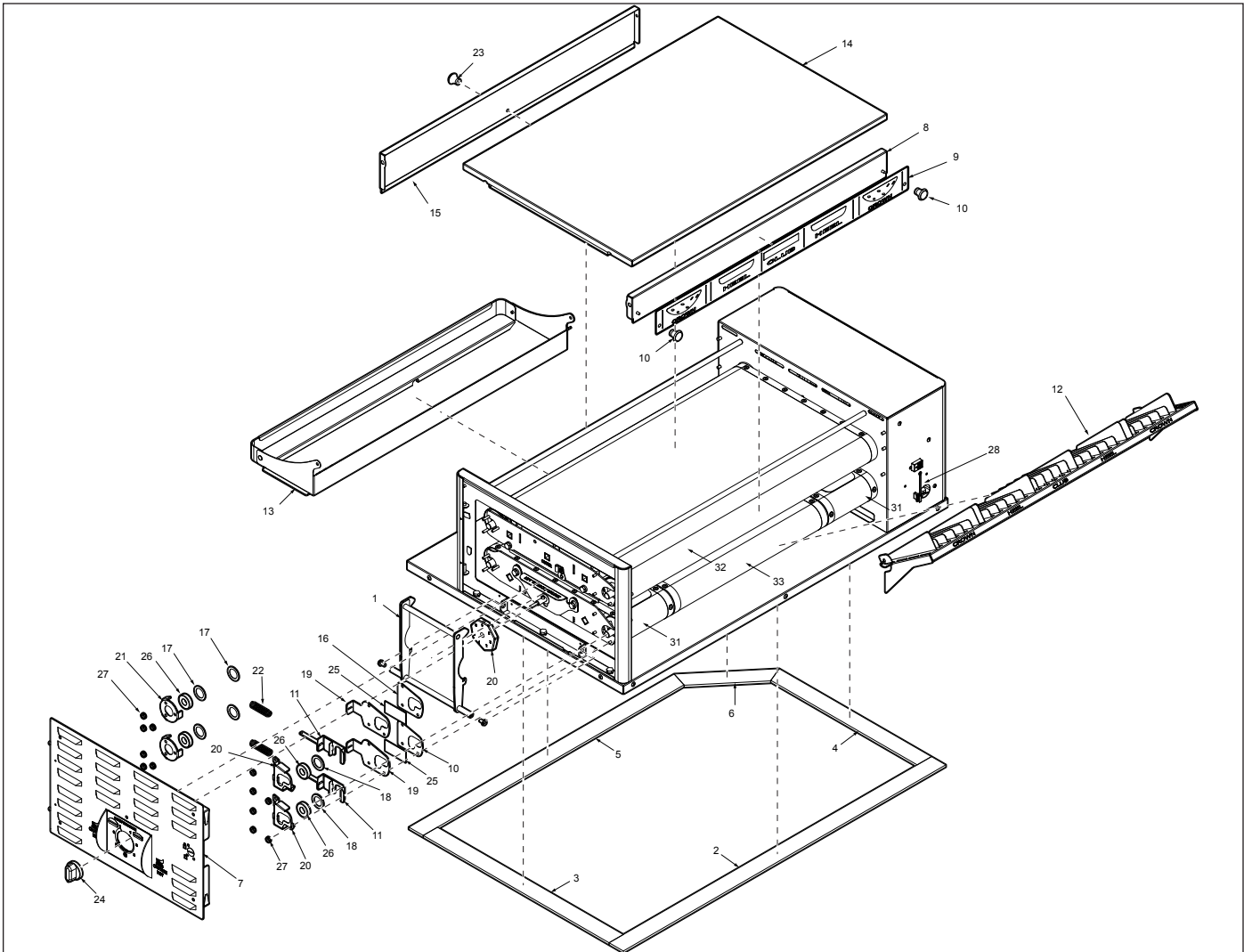

Item	Part No.	Description	Qty.	Item	Part No.	Description	Qty.
1	0022045	Weldment, Hinge Bracket - Bottom	1	18	0504320	Spacer 0.781 X 1.125 X 0.06"	4
2	0200329	Base Gasket, 33.86" Lg	1	19	0506957	Plate, Tensioner Rh	2
3	0200330	Base Gasket, 19.52" Lg	1	20	0506958	Bracket, Tensioner	2
4	0200340	Base Gasket, 15.99" Lg	1	21	0506959	Retainer, Bearing	2
5	0200341	Base Gasket, 27.86" Lg	1	22	0600158	Spring, Roller Tension	4
6	0200342	Base Gasket, 7.83" Lg	1	23	2100247	Knob	1
7	0013036	Side Door Assembly	1	24	2100253	Knob, 1/4" Shaft, Push-On	1
8	0022107	Weldment, Front Cover	1	25	2100334	Thrust Strip, Teflon	4
9	1001568	Label, Product	1	26	2150285	Bearing, Single Groove S/S	6
10	2100247	Knob	2	27	308P143*	Nut, Hex 'Keps' #8-32	1
11	0021724	Weldment, Bearing Brkt & Spring Guide - Rh	2	28	4060450	Cap, Usb W/Lanyard	1
12	0022046	Weldment, Bun Feeder	1	29	2150347	Cam	2
13	0022047	Weldment, Bun Stopper	1	30	7000799	Belt Replacement Kit Incl items 31, 32, and 33)	1
14	0022048	Weldment, Top Cover	1	31	7000795	Crown Belt	2
15	0022108	Weldment, Back Cover	1	32	7000796	Main Belt	1
16	0200331	Mica, Spacer Front	2	33	7000797	Heel/Club Belt	1
17	0400438	Spacer, 1.25Od X .03Thk, Nomex	4				

* Available in packages of ten (10).

REPLACEMENT PARTS (continued)

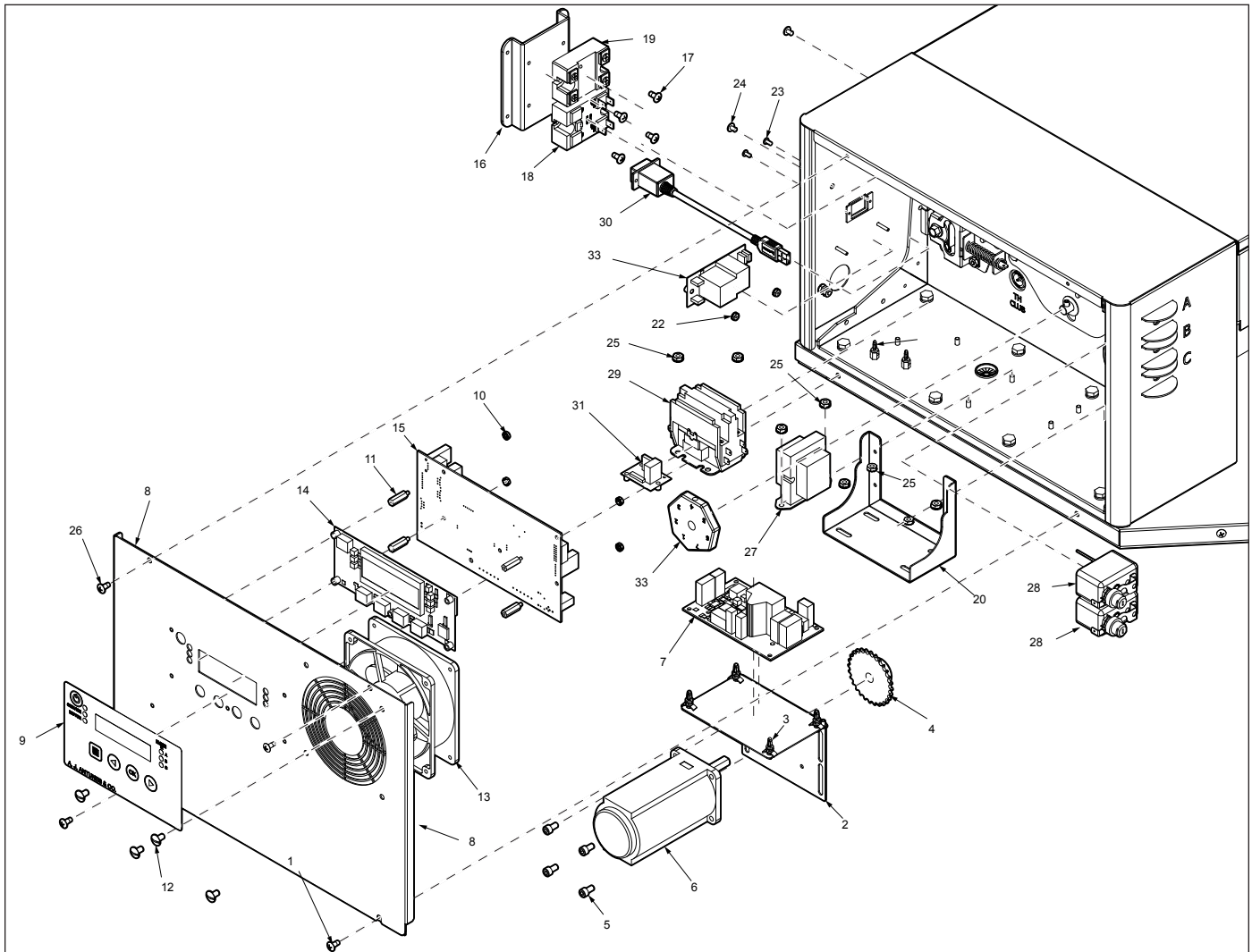

Item	Part No.	Description	Qty.	Item	Part No.	Description	Qty.
1	3080157	Screw, Tap 8-32 X 3/8"Lg	11	18	4050240	Relay, Solid State Dual Pole W/Conn-Recept	1
2	0506961	Plate, Motor Mounting	1	19	4051010	Relay, Random Phase, Solid State-50A1	1
3	21000-0046	Standoff, 1/4" Locking Pcb	4	20	0506946	Bracket, Motor Mounting	1
4	2150295	Sprocket, 25B28 .395" Bore	1	21	21000-0043	Spacer, 3/8 Cbs Thread Female	2
5	3100199	Scr, #10-32 X 3/8 Lg Socket Hd Cap	4	22	304P105*	Nut, Hex 'Keps' #4-40	1
6	7001041	Drive Motor Kit	1	23	304P114*	Screw, Mach #4-40 X 1/4"	1
7	7001040	Motor Board Kit	1	24	306P104*	Screw, Mach. #6-32 X 1/4"	2
8	0022055	Weldment, Cover Side, Control Hsg	1	25	308P143*	Nut, Hex 'Keps' #8-32	1
9	1001569	Label, Control	1	26	308P157*	Screw, Tap 8-32 X 3/8"Lg	1
10	304P105*	Nut, Hex 'Keps' #4-40	1	27	4010187	Transformer, 240 Vac/12Vac	1
11	304P117*	Hex Spacer, Male-Female 4-40 X 3/4"Lg	1	28	4030352	Thermostat, Hi-Limit 700°F	2
12	310P109*	Screw, Mach. #10-32 X 3/8"	1	29	4050236	Contactor, 2 Pole No	1
13	4000132	Fan, Blower	1	30	4060451	Usb, A-F Pnl Mount/A-M Shield	1
14	7001043	Display Board Kit	1	31	4070198	Snubber Board	1
15	7001042	Main Board Kit	1	32	4070221	Varistor Board	1
16	0506156	Heat Sink, Relay	1	33	2150347	Cam	2
17	308P157*	Screw, Tap 8-32 X 3/8"Lg	4				

* Available in packages of ten (10).

REPLACEMENT PARTS (continued)

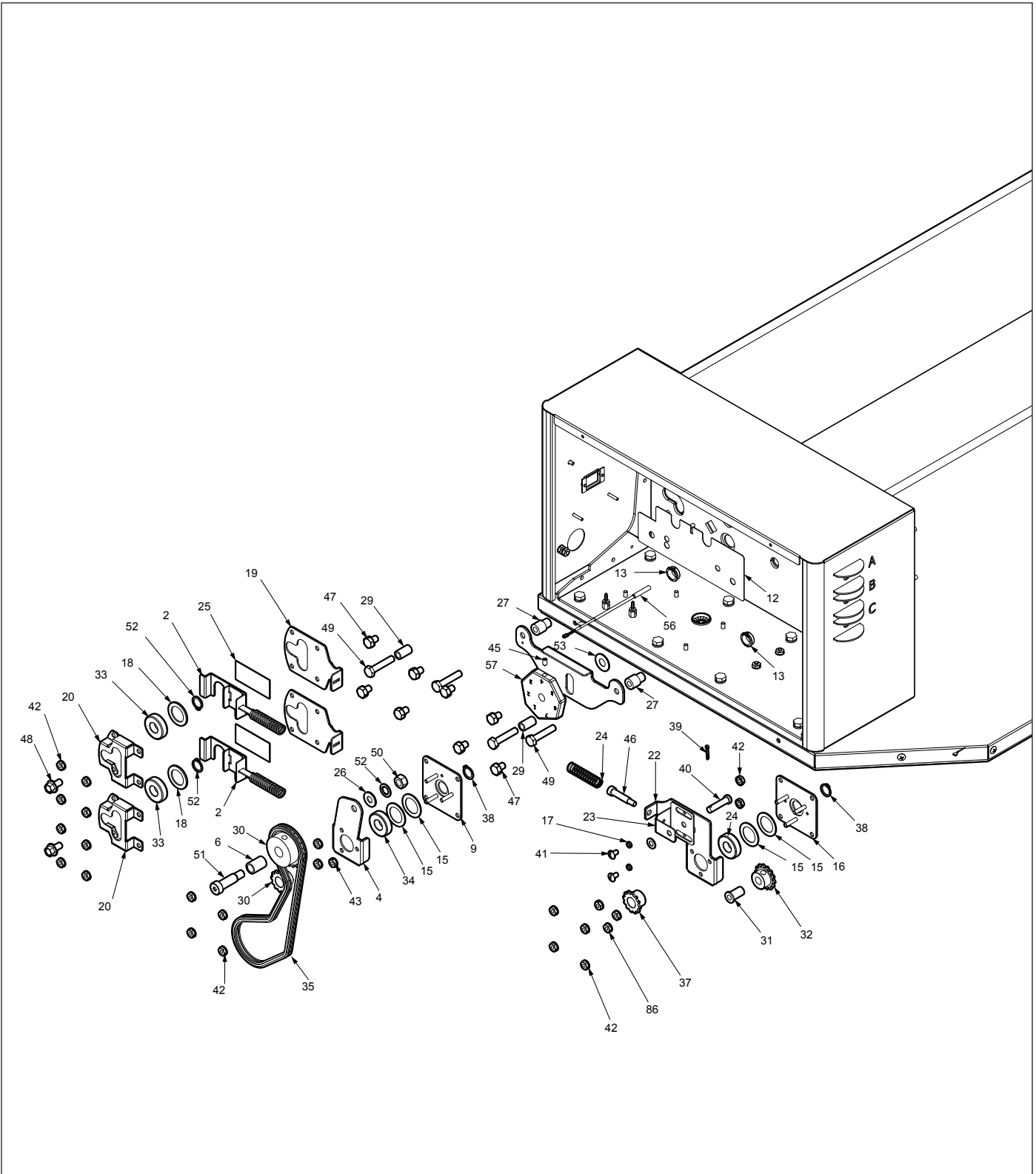

NOTE: See Page 20 for Parts List.

REPLACEMENT PARTS (continued)

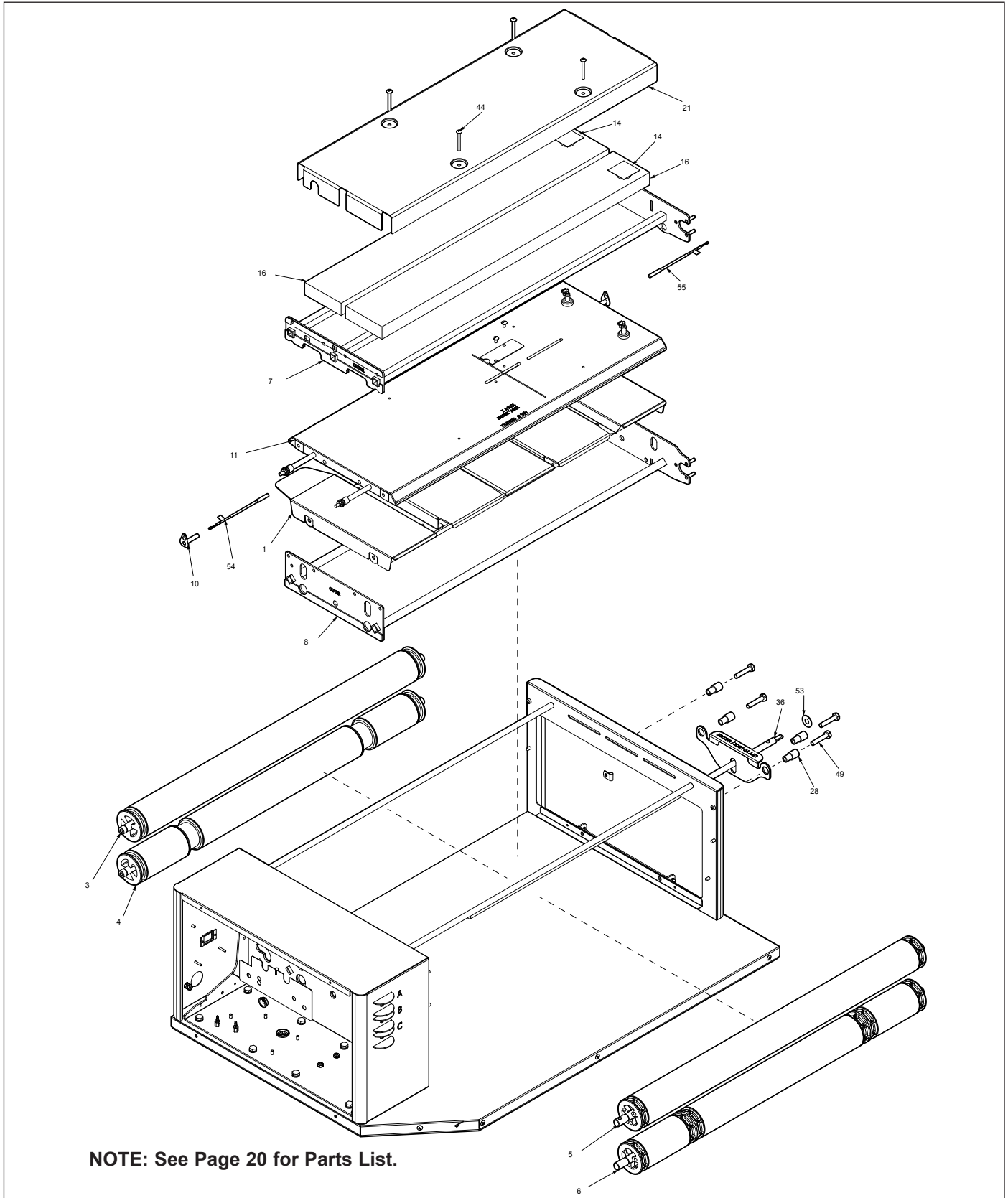

REPLACEMENT PARTS (continued)

Item	Part No.	Description	Qty.
1	0013035	Adj. Platen Assembly	1
2	0021725	Weldment, Bearing Bracket & Spring Guide - LH	2
3	0022000	Weldment, Idler Roller Front Top	1
4	0022001	Weldment, Idler Roller Rear Top	1
5	0022002	Weldment, Drive Roller Front Bottom	1
6	0022003	Weldment, Drive Roller Rear Bottom	1
7	0022020	Weldment, Top Frame	1
8	0022035	Weldment, Bottom Frame	1
9	0022054	Front Bearing Plate Weldment	1
10	0022134	Weldment, Thermocouple Tube	2
11	0100286	Platen, Main 208 Vac, 3600W	1
12	0200332	Control Hsg Mica Insulation	1
13	0400119	Bushing, Shorty 5/8"	2
14	0400290	Insulator, Electrical	2
15	0400438	Spacer, 1.25Od X .03Thk, Nomex	2
16	0400445	Main Platen, Insulation	2
17	0502199	Spacer	2
18	0504320	Spacer 0.781 X 1.125 X 0.06"	4
19	0506144	Plate, Tensioner Rh	2
20	0506163	Bracket, Tensioner	2
21	0506972	Plate, Insulation	1
22	0507151	Bracket, Bearing Retainer, Bottom	1
23	0507153	Retainer, Chain Tensioner Sprocket	1
24	0600150	Spring, Roller Tension	1
25	2100334	Thrust Strip, Teflon	4
26	2120118	Washer, Flat	1
27	2120253	Spacer, Upper Locking Plate, Control Side	2
28	2120254	Spacer, Upper Locking Plate, End Side	4
29	2120255	Spacer, Upper Locking Plate, Control Side	2
30	2150193	Sprocket, 25B24 1/2" Bore	1

Item	Part No.	Description	Qty.
31	2150250	Bearing, Flanged	1
32	2150251	Sprocket, 25B14 3/8" Bore	1
33	2150285	Bearing, Single Groove S/S	7
35	2150380	Chain, Drive (64 Links)	1
36	2150386	Cam Shaft	1
37	2150392	Sprocket, 25B12 1/2" Bore	1
38	3000123*	Ring, Retaining, External	1
39	303P115*	Cotter Pin-1/16"	1
40	303P133*	Pin, Clevis	1
41	308P127*	Screw, Mach. #8-32 X 5/16"	1
42	308P143*	Nut, Hex 'Keps' #8-32	1
43	308P143*	Nut, Hex 'Keps' #8-32	1
44	308P341*	#8-32 X 1.5" Lg Truss Head Screw	1
45	310P187*	Screw Set, #10-32 X 3/8 Hex Socket-Cone Point	1
46	310P207	Hex Socket Shoulder Screw, #10-32 X 1" Lg	1
47	325P174*	Screw, Machine Hex Hd 1/4-20 X 3/8	8
48	325P176*	Screw, Flange Hex Head Cap	2
49	325P193*	Screw, Hex Head, #1/4-20 X 1.375", S.S.	1
50	331P101*	Nut, Hex 5/16 - 18	1
51	3310103	Shoulder Bolt 3/8" X 1"	1
52	331P106*	Lock Washer	1
53	3380117	Washer, 3/8" Pffe	2
54	4050214	Thermocouple Type "K" (Open End)	1
55	4051022	Thermocouple Type "K" (Open End), 52" Lg	1
56	4051023	Thermocouple Type "K" (Open End), 32" Lg	1
57	2150347	Cam	2

* Available in packages of ten (10).

WIRING DIAGRAM

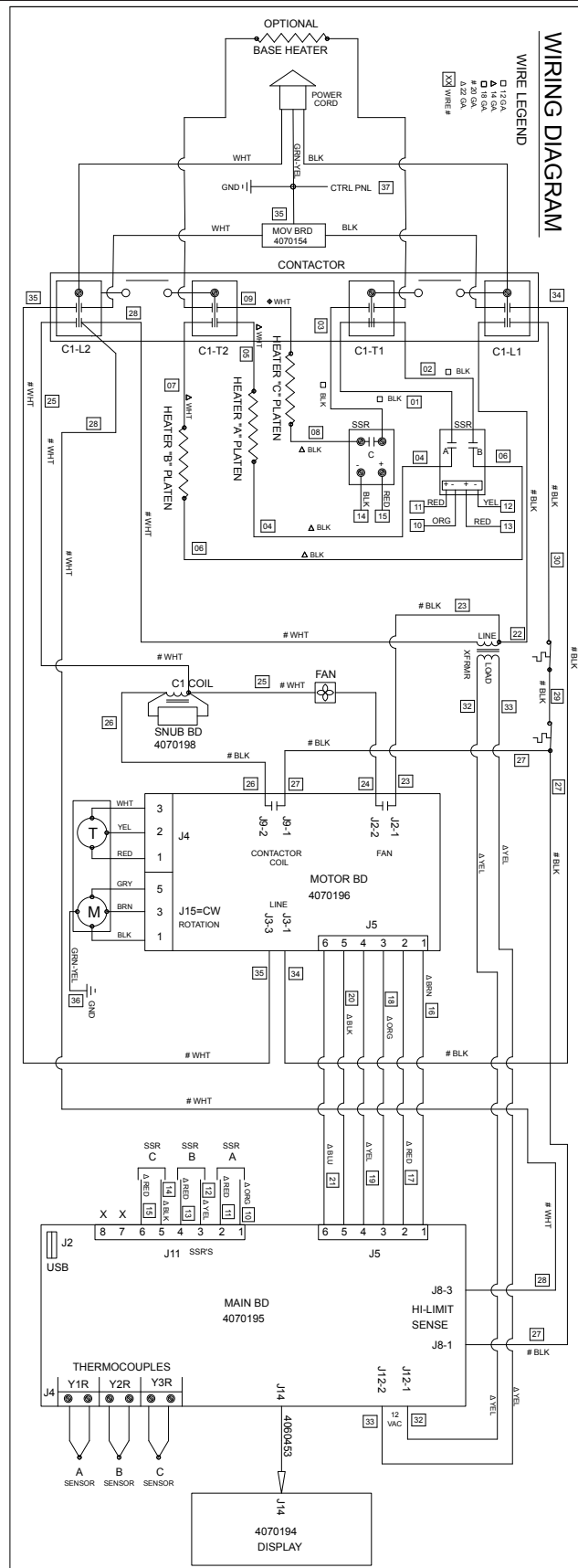



A.J. Antunes & Co.

We exist to make our customers successful.

A.J. Antunes & Co.
Headquarters/Manufacturing
Carol Stream, Illinois 60188 USA
Phone: (630) 784-1000
Toll Free: (800) 253-2991
Fax: (630) 784-1650

Antunes Equipment
Manufacturing (Suzhou) Ltd.,
Suzhou, Jiangsu, China 215011
Phone: 86-512-6841-3637
Toll Free: 400-0-7878-22
Fax: 86-512-6841-3907

www.ajantunes.com